

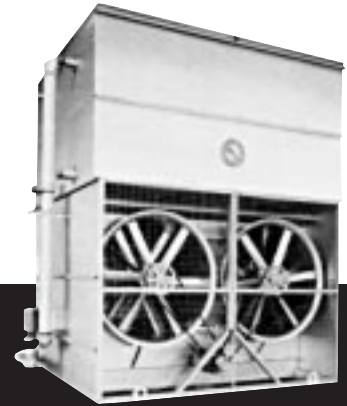

Series V & Low Profile

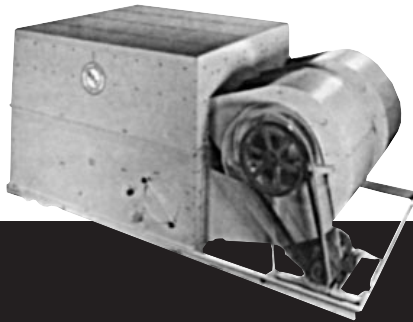

COOLING TOWERS CLOSED CIRCUIT COOLING TOWERS EVAPORATIVE CONDENSERS

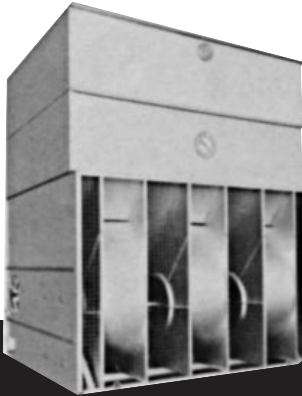

Operating and Maintenance Instructions

Baltimore Aircoil Company Series V equipment has been designed to give long, trouble-free service when properly installed, operated, and maintained. To obtain optimum performance and maximum service life, it is important that a program of regular inspection and maintenance be developed and carried out. This bulletin is published as a guide to establishing such a program.

Included in the bulletin are the recommended services for start-up, operation, and shutdown and the approximate frequency for each. **Note that the recommendations on frequency of service are minimums and where operating conditions are severe, the services should be performed more often.** For each required service, follow the procedures outlined under the "Maintenance Procedures" section of this bulletin. The VT1, VTO, VTL, VF1, VFL, VC1, VC2, and VCL models are illustrated in a cutaway form on page 2, 3, 4 and 5 with the major points of inspection and service identified. A copy of the unit certified drawing should also be available for reference. If you need additional information about the operation or maintenance of this equipment that is not covered in this bulletin, contact the local B.A.C. Representative. Their name and telephone number are on a label at the connection end of the unit.

Table of Contents

	Page
Construction Details	2-5
Operation and Maintenance Schedule	6
Operation and Maintenance	7
Initial and Seasonal Start-Up	7
After 24 Hours	7
Seasonal Shutdown	7
Maintenance Procedures	8
Cold Water Basin	8
Make-Up Valve	8
Fan Shaft Bearings	9
Fan Motor Bearings	10
Locking Collars	10
Adjustable Motor Base	10
Fan Belt Adjustment	11
Fan Drives	11
Spray Nozzles and Heat Transfer Section	11
Corrosion Protection	12
Cold Weather Operation	12
Water Treatment	14
Corrosion & Scale Control	14
Biological Control	15
Factory Authorized Parts	15



Baltimore Aircoil

Construction Details

SERIES V

MODEL VT1 AND VTO COOLING TOWERS

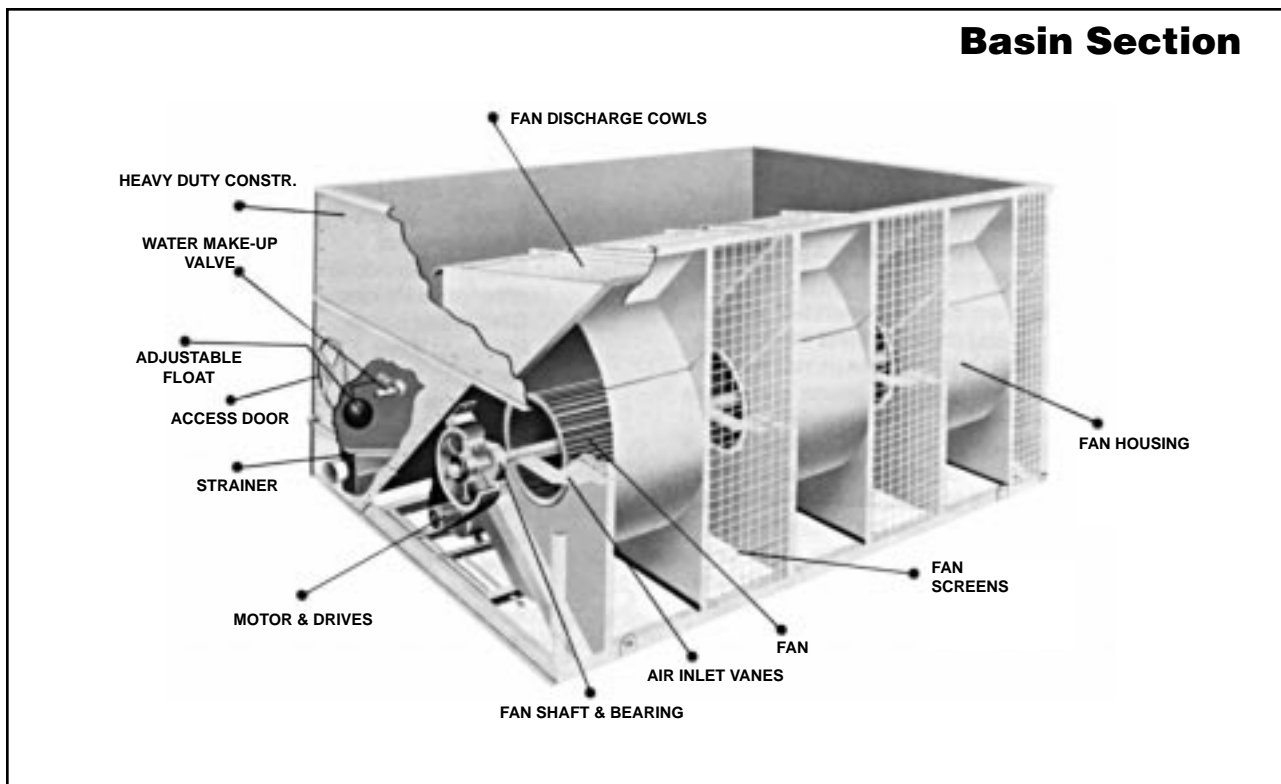
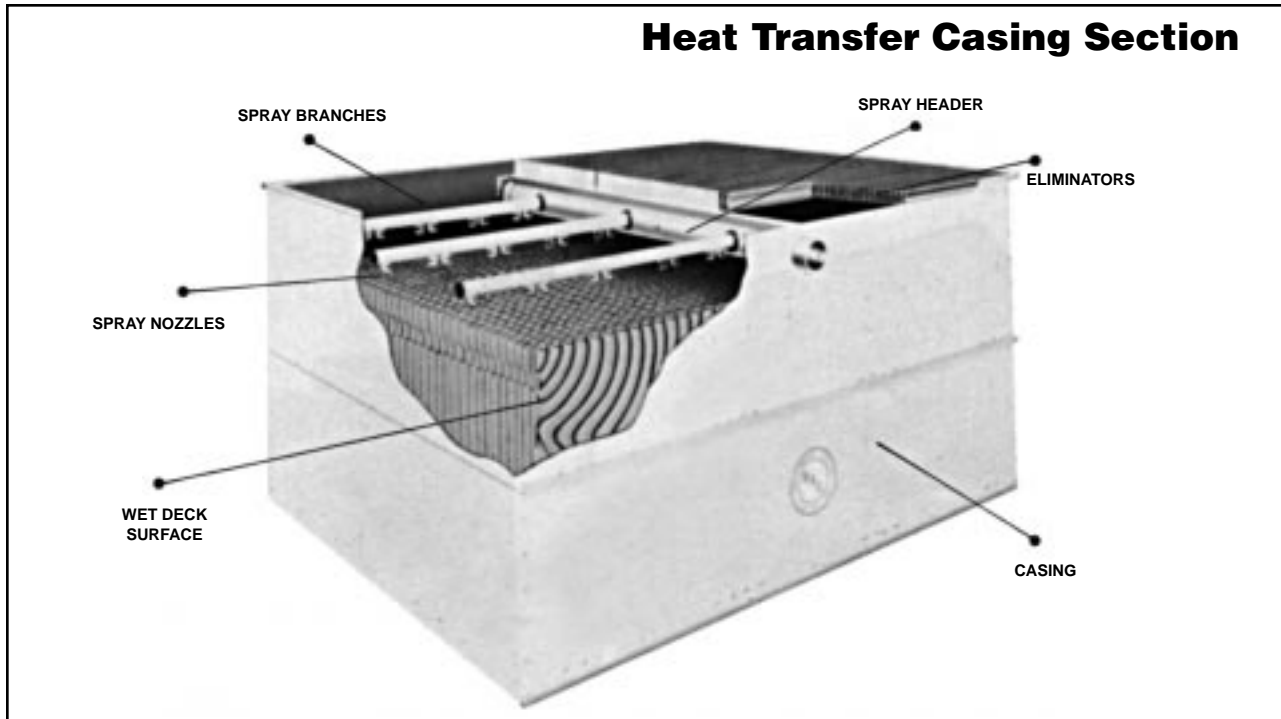

Construction Details

SERIES V

MODEL VF1 CLOSED CIRCUIT COOLING TOWERS

MODEL VC1 EVAPORATIVE CONDENSERS

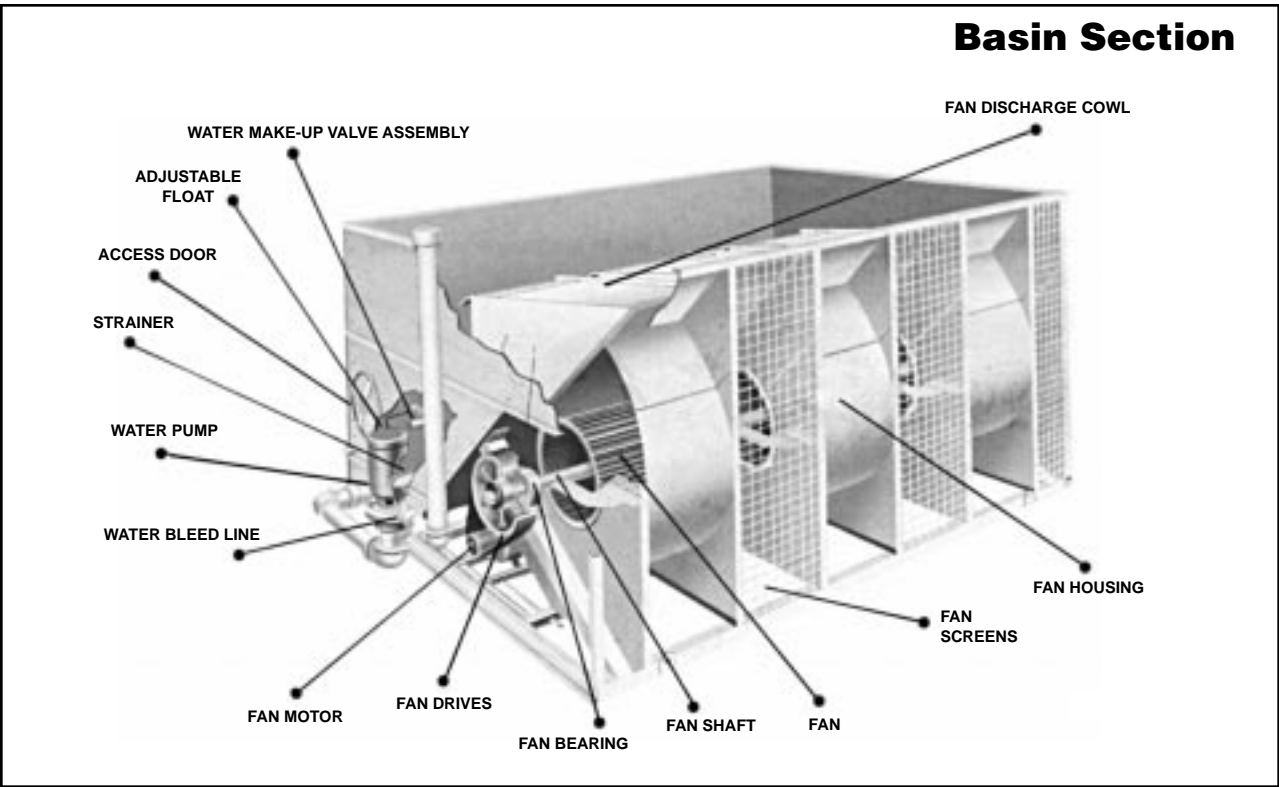
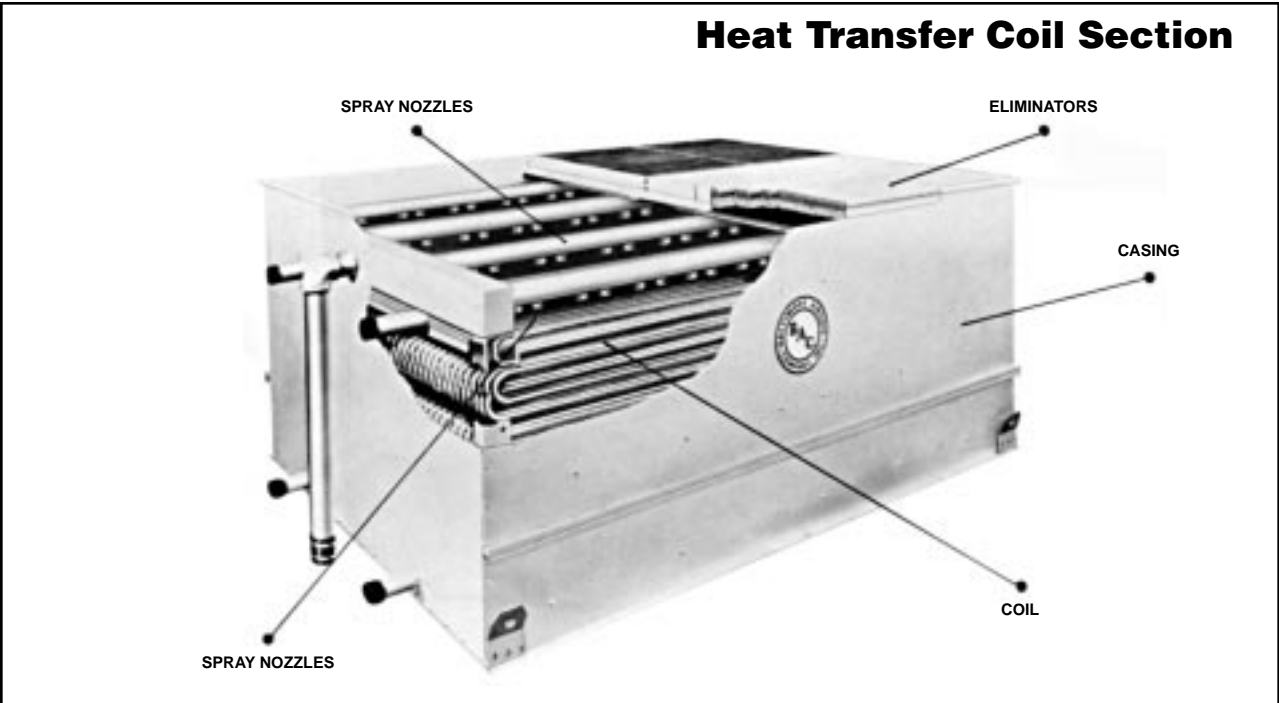

Construction Details

SERIES V

VC2 EVAPORATIVE CONDENSERS

Heat Transfer Coil Section

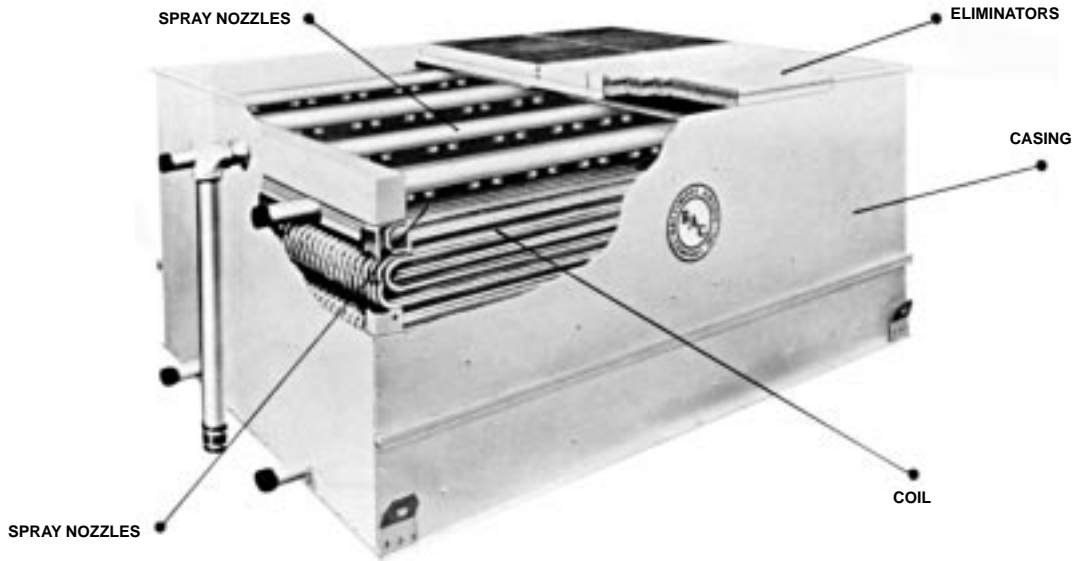

Basin Section

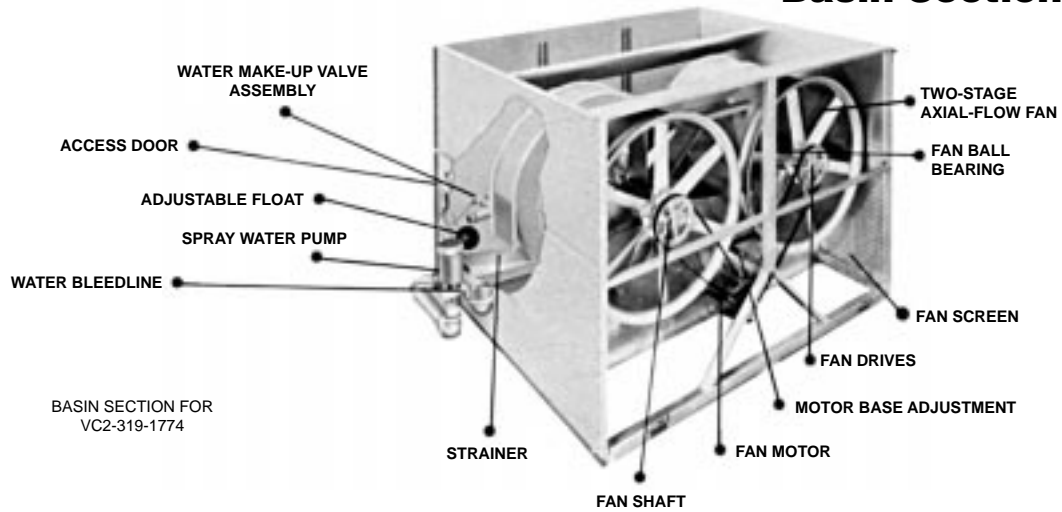

PUMP END

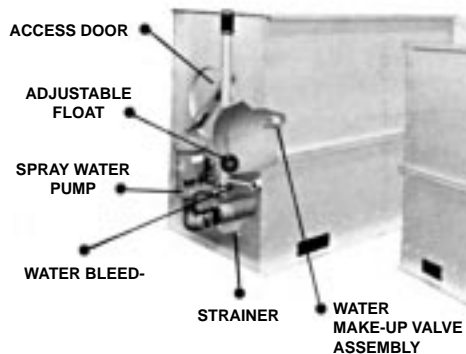

FAN END

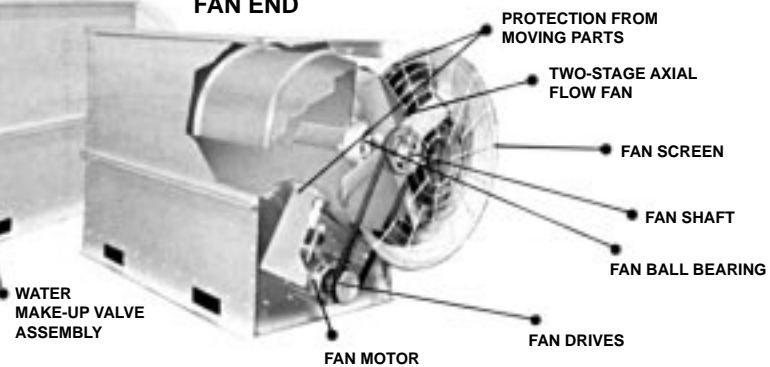

BASIN SECTION FOR
VC2-N138-N446

Construction Details

LOW PROFILE SERIES V

MODEL VTL COOLING TOWERS

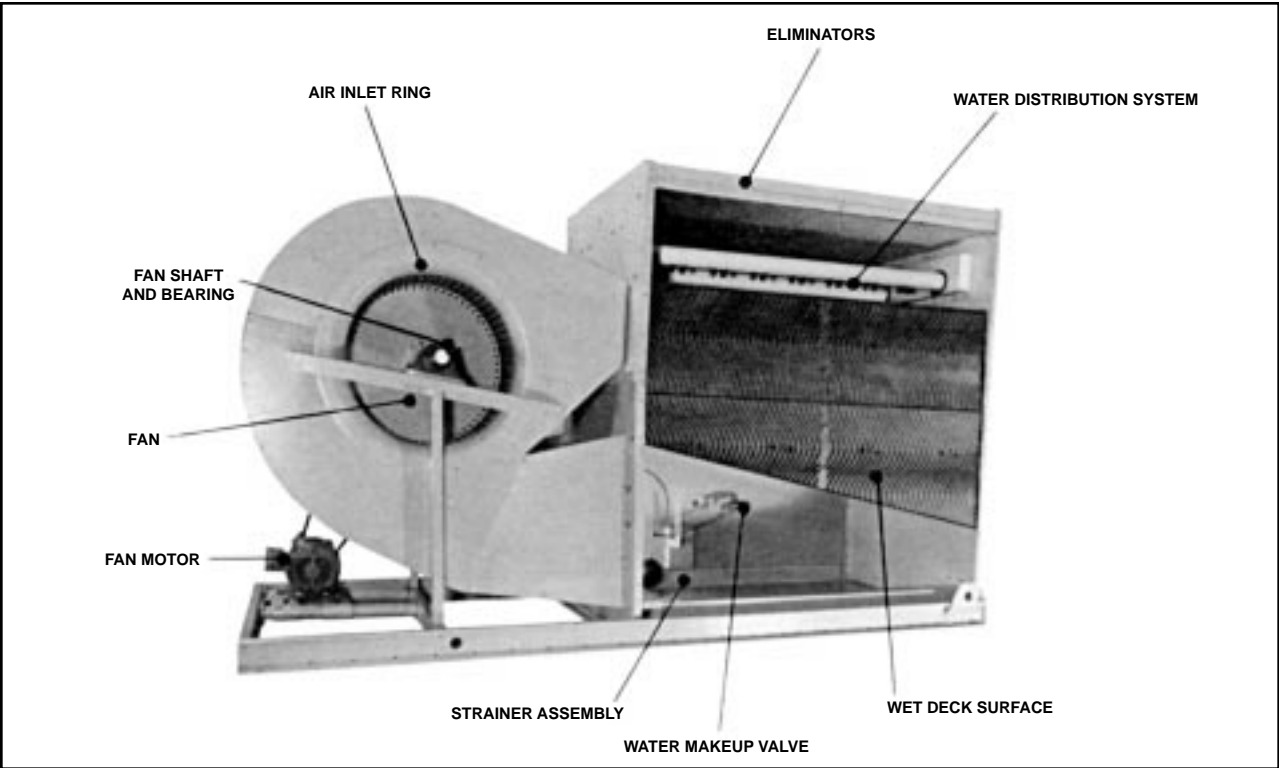

MODEL VFL CLOSED CIRCUIT COOLING TOWERS MODEL VCL EVAPORATIVE CONDENSERS

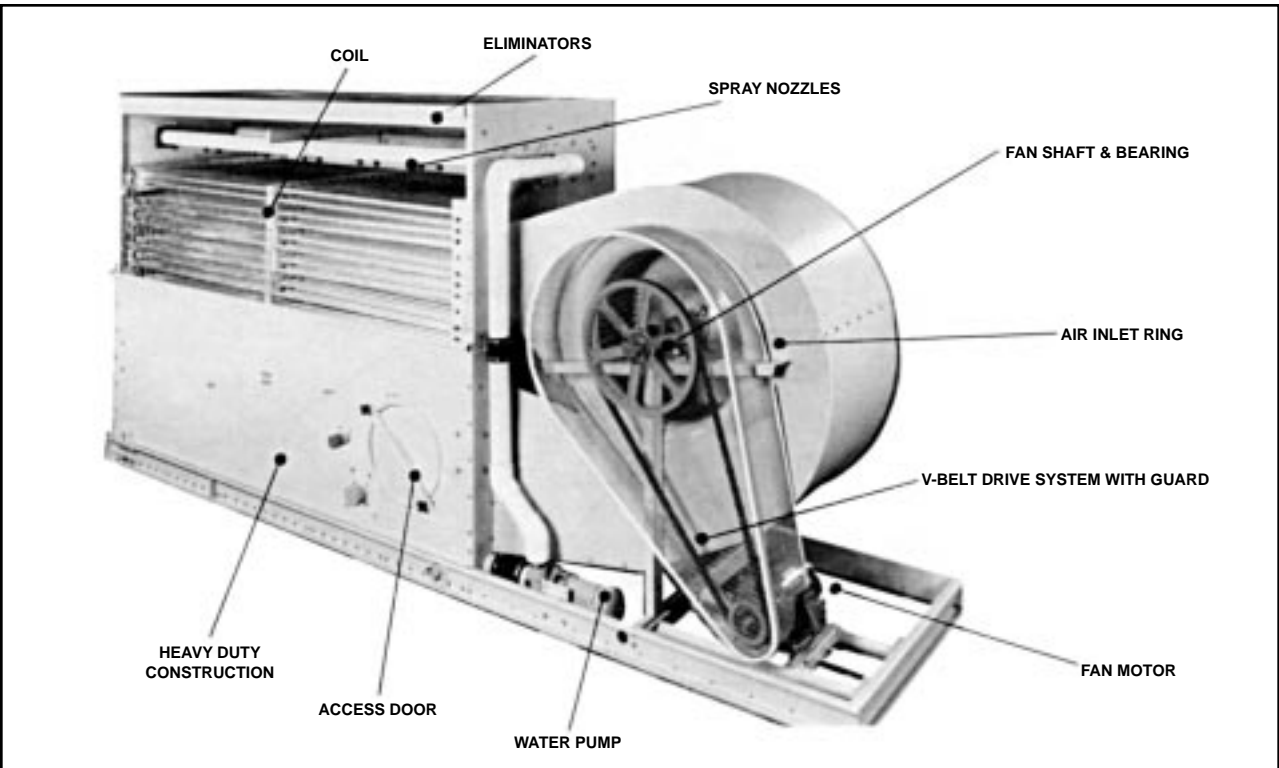

Operation and Maintenance Schedule

TABLE 1. Recommended Maintenance Services for Series V and Low Profile Series V Equipment.

TYPE SERVICE	Start-Up	Monthly	Every Six Months	Shutdown	Annually	Ref. Page
Inspect General Condition of Unit	X	X				7
Clean Debris from Unit	X	X		X		7
Clean and Flush Basin	X	X		X		7
Clean Basin Strainer	X	X		X		7
Check and Adjust Basin Water Level	X	X				8
Inspect Heat Transfer Section	X	X				11
Inspect Spray Nozzles	X	X				11
Check and Adjust Fan Belt Tension	X	X				11
Check and Adjust Bleed Rate	X	X				14
Check Operation of Make-up Valve	X	X				8
Check Unit for Unusual Noise or Vibration	X	X				7
Check Fan Bearing Locking Collars	X		X			10
Check Motor Voltage and Current	X		X			7
Lubricate Fan Shaft Bearings	X		X	X		9
Lubricate Fan Motor Bearings	X					10
Lubricate Motor Base Adjusting Screw	X		X	X		10
Check Fan for Rotation Without Obstruction	X					7
Check Fan and Pump Motor for Proper Rotation	X					7
Drain Basin and Piping				X		7
Inspect Protective Finish					X	12

WARNING: Before performing any maintenance or inspection, make certain that all power has been disconnected and locked in the off position.

SAFETY: The operation, maintenance, repair of this equipment must be undertaken only by qualified personnel. All qualified personnel should be thoroughly familiar with the equipment, the associated system and controls, and the procedures set forth in this manual. Proper care, procedures, and tools must be used in handling, lifting, installing, operating, maintaining and repairing this equipment to prevent personal injury and/or property damage.

Lockout Warning: For the protection of authorized service and maintenance personnel, each fan and pump motor associated with this equipment must be installed with a lockable disconnect switch located within sight of the cooling tower. No service work should be performed on or near the fans, motors, and drives or inside the unit without first ensuring the fan and pump motors have been disconnected and locked out.

Electrical Hazard: All electrical, mechanical, and rotating machinery constitute a potential hazard, particularly for those not familiar with its design, construction, and operation. Accordingly, adequate safeguards (including the use of protective enclosures where necessary) should be taken with this equipment both to safeguard the public (including minors) from injury and to prevent damage to the equipment, its associated system, and the premises.

WARNING: PVC eliminators on this product are not designed to support the weight of a person or to be used as a storage or work surface for any equipment or tools. Use of these PVC eliminators as walking, working or storage surface may result in injury to personnel or damage to equipment. Units with PVC eliminators should not be covered with a clear plastic tarpaulin.

Access: Depending upon site conditions, it also may be necessary to install bottom air inlet screens, ladders, safety cages, stairways, access platforms, and handrails and toeboards for the safety and convenience of authorized service and maintenance personnel.

At no time should this equipment be operated without all fan screens, access panels, and access doors in place.

Caution: The recirculating water system may contain chemicals or biological contaminants, including Legionella, which could be harmful if inhaled or ingested. Accordingly, personnel who may be exposed directly to the discharge airstream and the associated drift, mists generated during operation of the water distribution system and/or fans, or mists produced by high pressure water jets or compressed air, should these be used to clean portions or components of the recirculating water system, should wear **respiratory protection equipment** approved for such use by OSHA and/or local occupational safety and health authorities.

WARRANTIES—Please refer to the Limitation of Warranties applicable to and in effect at the time of sale/purchase of these products.

FREEZE PROTECTION—These products must be protected by mechanical and operational methods against damage and/or reduced effectiveness due to possible freeze-up. Please refer to the Cold Weather Operation guidelines (page 12) or contact the local B.A.C. Representative for recommended protection alternatives.

Operation and Maintenance

INITIAL AND SEASONAL START-UP:

Prior to initial start-up or after a shut down period, the unit should be thoroughly inspected and cleaned:

1. Clean all debris from inlet air screens, fans, eliminators, heat transfer sections, and the cold water basin.
2. Drain the cold water basin (with basin strainers in place) and flush to remove accumulated dirt.
3. Remove, clean, and replace basin strainers.
4. Turn the fan(s) by hand to ensure rotation without obstruction.
5. Check the locking collar on each fan bearing assembly and tighten as required.
6. Check and, if necessary, adjust the fan belt tension.
7. Prior to seasonal start-up, lubricate the fan shaft and motor bearings. The ball bearings are factory lubricated, but should be relubricated if the unit has been sitting on site for more than a year before start-up.
8. Check float operated make-up valve to be sure it is operating freely.
9. Fill the cold water basin with fresh water to the overflow level.
 - a. The initial biocide treatment should be applied at initial start-up or before restart-up, where the basin was completely drained. (see Water Treatment section)
 - b. Following a shutdown period, where the basin was not completely drained: **it is recommended that an initial shock treatment of appropriate biocides be administered at restart-up to eliminate accumulated biological contaminants.**
10. Set the float on the make-up valve to shut off the valve when the float is approximately 1/2" below the overflow level.
11. On Closed Circuit Cooling Towers and Evaporative Condensers, start the pump and check for the proper rotation as indicated by the arrow on the pump cover. On installations where the unit pump was not furnished by the factory, a globe valve should be installed in the pump discharge line and the pump flow rate adjusted to the correct water flow and pressure (2 psig at spray header connection). **Pressure greater than 10.0 psig may cause damage to the distribution system.**
12. Inspect the spray nozzles and heat transfer section.
13. Start the fan and check for the proper rotation as indicated by the arrow on the fan housing.

14. Check the voltage and current of all three legs of the fan and pump motors. **The current should not exceed the nameplate rating.** After prolonged shut-downs, the motor insulation should be checked with a megger insulation tester prior to restarting the motor. **To prevent motor overload, do not operate fan motor without design water flow over unit.**
15. Check the bleed system to be sure it is fully functional and the bleed rate has been properly adjusted prior to putting the unit into operation (see "Water Treatment").

AFTER 24 HOURS:

After 24 hours of operating under load, the following services should be performed:

1. Check the unit for any unusual noise or vibration.
2. Check the operating water level in the cold-water basin. Adjust make-up float valve if necessary.
3. Readjust the fan belt tension.
4. Inspect the spray nozzles and heat transfer section.

OPERATION:

During operation, the unit should be inspected, cleaned, and lubricated on a regular basis. The required services and recommended frequency for each are summarized in Table 1 on page 6 of this bulletin.

SEASONAL SHUT-DOWN:

The following services should be performed whenever the unit is to be shut-down for more than three days:

1. Drain the cold water basin and all piping that will be exposed to freezing temperatures.
2. Clean and flush the cold water basin with the basin strainers in place. Leave the cold water basin drain open so rain and melting snow will drain from the unit.
3. Clean the basin strainers and reinstall.
4. Lubricate the fan shaft and motor bearings, motor base, and motor base adjusting screw.
5. Close the shut-off valve in make-up water line and drain all exposed make-up water piping.
6. Inspect the protective finish on the unit. Clean and refinish as required.
7. For VF1 and VFL closed circuit cooling towers, follow the coil freeze protection guidelines explained on page 13.

Maintenance Procedures

COLD WATER BASIN

The cold water basin should be inspected regularly. Any trash or debris which may have accumulated in the basin or on the strainers should be removed.

Each month, the entire cold water basin should be drained, cleaned, and flushed with fresh water to remove the silt and sediment which normally collects in the basin during operation. **If not removed periodically, this sediment can become corrosive and cause deterioration of the protective finish.** When flushing the basin, the strainers should be left in place to prevent the sediment from re-entering the system. After the basin has been flushed, the strainers should be removed, cleaned, and replaced before refilling the basin with fresh water.

CAUTION: Do not use acid to clean the strainers.

The operating water level in the cold water basin will vary somewhat with system thermal load (evaporation rate), the bleed rate employed and the make-up water supply pressure. Because the typical winter load is less than the summer load, the winter evaporation rate is frequently less than the summer evaporation rate. With this reduced evaporation rate in winter, the water level in the cold water basin will increase unless the float is re-adjusted. **The operating water level should be checked monthly and the float re-adjusted as necessary to maintain the recommended operating level.**

The water level in the basin of equipment designed for remote sump operation is a function of the circulating water flow rate, water outlet connection size, quantity and location, and outlet piping size and configuration. The remote sump unit is supplied without a water make-up assembly and the sump operating level during remote sump operation is not adjustable.

MAKE-UP VALVE

A float operated mechanical water make-up assembly is furnished as standard equipment on all Series V and Low

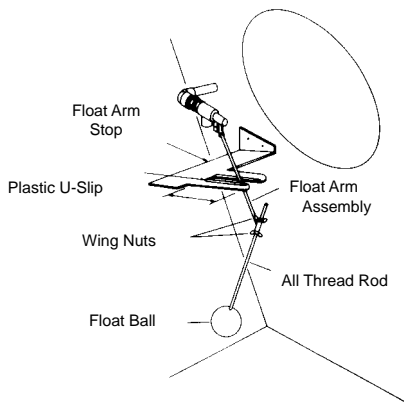

Figure 1 – Water Make-Up Valve Assembly

Profile Series V equipment unless the unit has been ordered with the optional electric water level control package or for remote sump application. It is located inside the unit cold water basin within easy reach from the access door at the connection end of each unit.

The standard make-up assembly (see Figure 1) consists of a bronze make-up valve connected to a float arm assembly and actuated by a large diameter polystyrene filled plastic float. The float is mounted on an all-thread rod which is held in place by wing nuts. The operating water level in the cold water basin can be adjusted by repositioning the float and all-thread rod using the wing nuts provided.

The make-up assembly should be inspected monthly and adjusted as necessary. The valve itself should be inspected annually for leakage and the valve seat replaced if necessary.

The make-up water supply pressure should be maintained between **15 and 50 psig** for proper operation of the valve.

To set the initial basin water level, adjust the wing nuts so that the make-up valve is completely closed when the water level in the cold water basin is 1/2" below the overflow connection. Under design thermal load and with average city water pressure (15 to 50 psig) at the valve, this setting should produce the operating water levels stated in Table 2. Note that if the thermal load is less than the design load at the time of unit start-up, the procedure may produce operating levels greater than that shown. It may be necessary to re-adjust the float in order to attain the recommended operating level. The unit basin should be closely monitored and water level adjusted as necessary during the first 24 hours of operation.

TABLE 2. Operating Water Level

MODEL NO.	OPERATING HEIGHT (measured from basin bottom)
VTL, VFL, VCL	5 1/2"
VF1-009 thru VF1-036, VC1-10 thru 135	13 1/2"
VF1-048, VC1-150 thru 205	16 1/2"
VF1-072, VC1-N208 thru N230	17"
VTO-12 TO VTO-116	12 7/8"
VTO-132 TO VTO-176	15 1/2"
All VT1-N, VF1-096, VF1-144N, VF1-192, VF1-288N, VC1-N243 thru N470, VC1-C216 thru C469	17"
All VT1, VTF1-144, VF1-216, VF1-288, VF1-432, VC1-386 thru 1608	14"
VC2-N138-N191	8 7/8"
VC2-N206-N235	9 5/8"
VC2-N261-N446	6"
VC2-319-1774	12 1/8"

Maintenance Procedures

(continued)

As an option, an electric water level control package is available in lieu of the above described mechanical make-up assembly. The package consists of a probe-type liquid level control assembly and a slow closing solenoid valve. Stainless steel electrodes, factory set at predetermined lengths, extend from a NEMA 4 electrode holder into the cold water basin. **These electrodes should be periodically wiped clean to prevent accumulations of scale, corrosion, sludge or biological growth from interfering with the electrical circuit.** With the electric water level control package, the water level is maintained at the recommended operating level regardless of the system thermal load. Therefore, it is not necessary, nor is it recommended that the operating level be adjusted. During initial and seasonal start-up, the probe-type level control assembly should be bypassed to fill the cold water basin to approximately 1/2" below the overflow connection.

Unit operation at the recommended water level will ensure that the unit basin contains sufficient water volume to prevent air entrainment in the circulating pump during system start-up and to provide sufficient excess basin capacity to accept the total system pull-down volume. The "total system pull-down volume" is the quantity of water suspended in the tower during pump operation plus that contained in the water distribution system, external piping, and any heat exchangers which could drain to the tower cold water basin when the circulating pump is shut down.

FAN SHAFT BEARINGS

The fan shafts on VTO, VT1, VTL, VF1, VFL, VC1, and VCL units are supported at each end by ball bearings (see Figure 2), each equipped with a lubrication fitting and locking collar. Models VTO-65 to 116, VF1-027, VF1-036, and VC1-72 thru 135 also have a sleeve bearing (see Figure 3) located midway on the shaft.

The fan shafts on VC2 units are supported by ball bearings (see Figure 2A) in the middle of the shaft with fans at each end. Each bearing is equipped with a lubrication fitting and locking collar. Lubrication lines are extended to the outside of the unit as standard.

Ball Bearings

Under normal operating conditions, the bearings should be greased every 2,000 operating hours or at least every six months. The bearings should also be greased at seasonal start-up and shut-down. Only lubricate the bearings with one of the following water resistant inhibited greases which are good for ambient temperatures ranging from -65°F to 250°F:

American – Rycon Premium #3

Exxon – Beacon #325

Shell – Aeroshell #7

Mobil – Mobilgrease #28

Chevron – SRI #3

Keystone – 84 EP Light

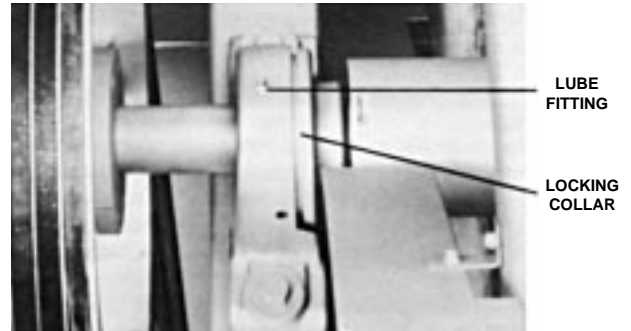

Figure 2 – Ball Bearing

Only lubricate the bearings with a hand grease gun. Do not use high pressure grease guns since they may rupture the bearing seals. When lubricating, purge the old grease from the bearing by gradually adding grease until a bead of new grease appears at the seal.

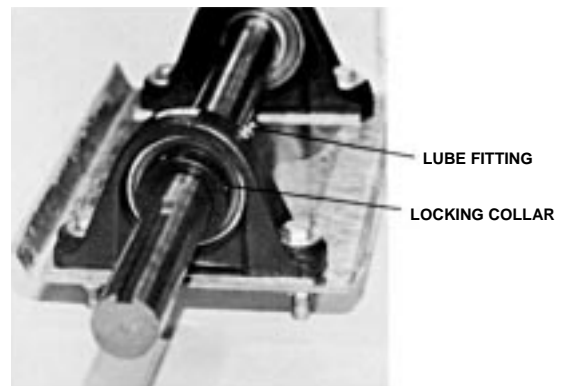

Figure 2A – Ball Bearing

Sleeve Bearings

Prior to start-up and during the first week of operation, the bearing oil cup must be refilled with an industrial-type mineral oil (see Table 3) to saturate the felt wick in the bearing reservoir. After the initial start-up, fill the bearing oil cup every 1,000 operating hours or at least every six months. When ambient temperatures below 0°F are expected, a light oil must be used. With such light oils, the bearing oil cup should be checked and refilled several times during the first several hours of operation until the bearings reach operating temperature.

Maintenance Procedures

(continued)

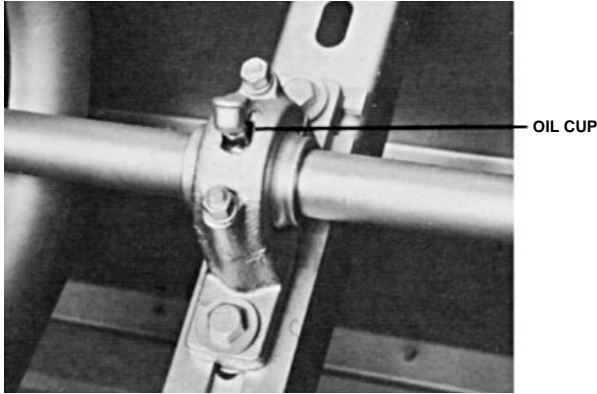

Figure 3 – Sleeve Bearing

TABLE 3. Sleeve Bearing Lubricants

TEMP AMBIENT	B.A.C. P/N	TEXACO	EXXON
70°F to 110°F	#582628PI	Regal R & O 320	Teresstic 220
30°F to 70°F		Regal R & O 150	Teresstic 100
5°F to 30°F	#582627PI	Regal R & O 32	Teresstic 32
-25°F to 5°F		Capella 32	

CAUTION: Do not use oils containing detergents for bearing lubrication. Detergent oils will remove the graphite in the bearing sleeve and cause bearing failure. Also, do not disturb bearing alignment by tightening bearing cap adjustment on a new unit as they are torque adjusted at the factory.

FAN MOTOR BEARINGS

All Totally Enclosed Fan Cooled (TEFC) Fan Motors have regreaseable bearings. The motor bearings should be lubricated as recommended in the motor manufacturer's operating instructions that are attached to the motor when the equipment ships from the factory.

LOCKING COLLARS

Each eccentric locking collar should be checked every six months to ensure that the inner bearing race is secured to the fan shaft. The locking collar can be set using the following procedure (see Figure 4):

1. Loosen the set screw.
2. Using a drift pin or centerpunch, tap the collar (in the hole provided) tangentially in the direction of rotation while holding the shaft.
3. Retighten the set screw.

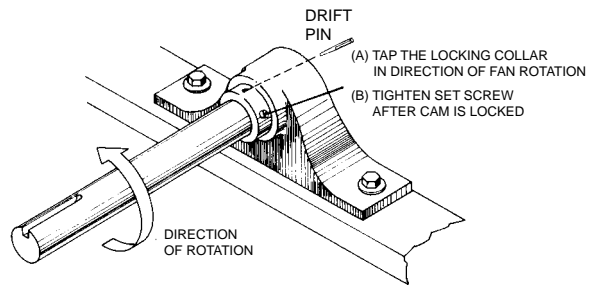

Figure 4 – Locking Collar Assembly

ADJUSTABLE MOTOR BASE:

The motor base slides and adjusting screw (See Figure 5) should be coated twice a year using a good quality corrosion inhibiting grease such as one of those recommended for lubricating the fan shaft bearings (see Page 9).

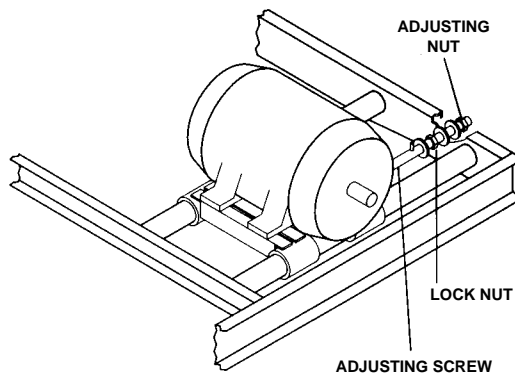

Figure 5 – Adjustable Motor Base
VTO, VT1, VTL, VF1, VFL, VC1, VCL

ADJUSTABLE MOTOR BASE:

The motor base hangers, hinges, and adjusting screw (See Figure 5A and 5B) should be coated twice a year using a good quality corrosion inhibiting grease such as one of those recommended for lubricating the fan shaft bearings (see Page 9).

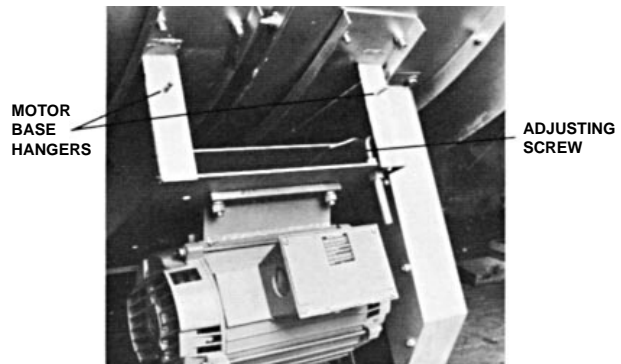

Figure 5A – Adjustable Motor Base
VC2-N138-N446

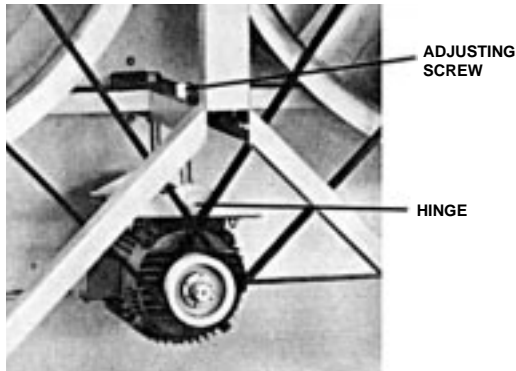

Figure 5B – Adjustable Motor Base VC2-319-1774

FAN BELT ADJUSTMENT

Some of the smaller axial fan models use individual V-belts, but most of the models use multi-groove, banded belts. **Belt tension should be checked and adjusted (as needed) every month.** To properly adjust the belt tension, position the fan motor so that moderate pressure on the belt midway between the sheaves will produce 1/2" deflection in centrifugal fan units and the deflection shown in Table 4 below for axial fan units. The position of the fan motor can easily be changed by adjusting the rod which extends from the frame to the motor base.

1. Loosen the locking nut (See Figure 5, 5a, 5b)
2. Rotate the adjusting nut
 - a. To loosen belt tension, turn clockwise (on models VTL, VFL and VCL turn counterclockwise).
 - b. To tighten belt tension, turn counterclockwise (on models VTL, VFL and VCL turn clockwise).
3. Tighten the locking nut – failure to do so may result in the motor base vibrating free, hence, loosening the belt tension.

Note: There should be no “chirp” or “squeal” when the fan motor is started.

TABLE 4. Fan Belt Deflection for VC2 Models

MODEL NO.	DEFLECTION (inches)
VC2-N138-N191	9/16"
VC2-N206-N235	11/16"
VC2-N261-N301	11/16"
VC2-N356-N446	13/16"
VC2-319-1774	13/16"

FAN DRIVES

The drive alignment should be checked annually to ensure maximum belt life. This can be done by placing a straightedge across both sheaves as shown in Figure 6. When the drive is properly aligned, the straightedge will contact all four points as indicated. If realignment is necessary, loosen the motor sheave and align it with the fan sheave. Allow approximately 1/4" for draw-up as the motor sheave is pulled tight on the bushing, then retighten the bushing screw:

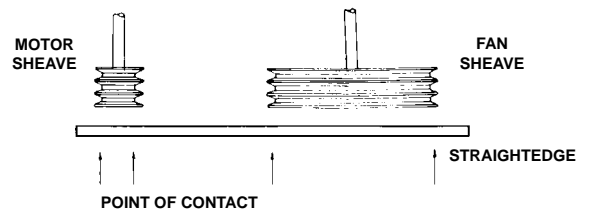

Figure 6 – Checking Sheave Alignment

MOTOR REPLACEMENT

On rare occasions, the fan motor will have to be replaced. On the VC2 models, make sure the drain holes are pointing in the downward direction. This may require that the end bell be reversed on some motors.

SPRAY NOZZLES AND HEAT TRANSFER SECTION

The spray nozzles and heat transfer section should be inspected and cleaned each month. The inspection procedure is as follows:

1. Shut off the fan, but leave the pump running.
2. Remove the eliminators.
3. Check to see if the nozzles are producing the spray pattern shown in Figure 7a for cooling towers or 7b for coil products.
4. Clean any nozzles which are clogged. If necessary, the nozzle and rubber grommet may be removed for cleaning.
5. Inspect the coil or wet deck surface. Any corrosion, damage, or obstructions must be corrected.
6. Some VF1, VFL, VC1, VC2, and VCL units are provided with an extended surface finned coil. During the winter season, when the ambient temperature is well below design, units with this coil can operate with the spray pump off. The coil is designed for seasonal dry operation followed by seasonal wet operation, and *not* for frequent cycling of the spray pump. **Frequent spray pump cycling may lead to excessive scale buildup.**

Caution: Do not use steam or high pressure water to clean cooling tower wet deck surface of materials other than steel.

Maintenance Procedures

(continued)

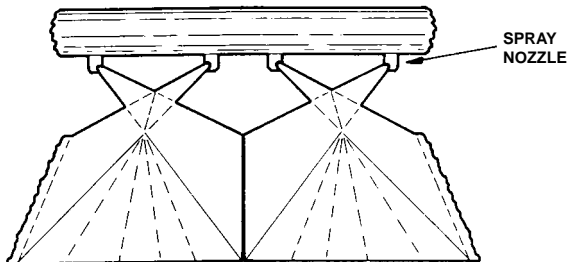

Figure 7a – Nozzle Spray Distribution (Cooling Towers)

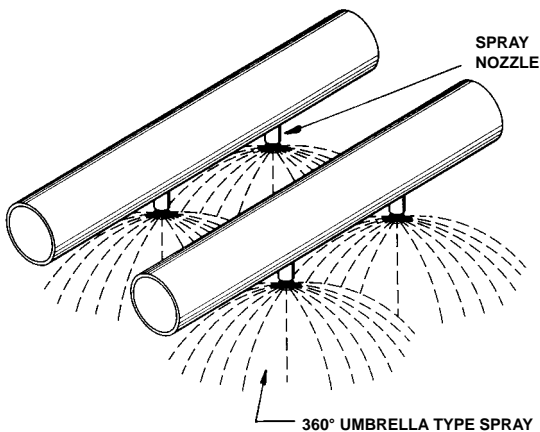

Figure 7b – Nozzle Spray Distribution (Coil Products)

CORROSION PROTECTION

Series V units are constructed entirely of corrosion-resistant materials. The wet deck surface and the eliminators of the VT1, VTO and VTL are made of polyvinyl chloride (PVC) which requires no protection against rot, decay, rust, or biological attack. The standard coil of the VF1, VFL, VC1, VC2, and VCL is constructed of all prime surface steel, hot-dip galvanized after fabrication. The balance of the construction in all units is either heavy-gauge galvanized steel, the optional BALTIBOND® Corrosion Protection System, or Type 304 stainless steel.

Galvanized Steel Construction

The standard Series V and Low Profile Series V units are constructed of hot-dip galvanized steel. **These units should be inspected annually.**

Inspect the inside of the unit for blemishes or corrosion on the galvanized steel. Affected areas should be thoroughly wire brushed and recoated with zinc-rich compound (ZRC).

BALTIBOND® Corrosion Protection System

The Series V and Low Profile Series V units can be constructed of hot-dip galvanized steel, protected with the BALTIBOND® Corrosion Protection System as an option. Scratches and scrapes on parts which do not require extraordinary corrosion protection can be touched up with a repair kit (B.A.C. Part No. 16-133P). In the unlikely event that the damage is more extensive than simple scratches or dents, contact your local B.A.C. Representative.

Cold Weather Operation

Series V and Low Profile Series V equipment can be operated in subfreezing ambient conditions provided proper measures are taken:

1. Protection against basin water freezing when the unit is idle.
2. Capacity control to prevent ice formation in heat transfer sections during operation.
3. Protection against coil freezing (VF1 and VFL Closed Circuit Cooling Towers and cooling circuits in VC1, VC2, and VCL Evaporative Condensers).

Cold weather applications should be reviewed with the B.A.C. Representative in your area to ensure that the unit selection, location, control, and accessories are adequate for reliable operation. Listed below are general guidelines, which should be followed to minimize the possibility of freeze-up.

PROTECTION AGAINST BASIN WATER FREEZING

When the unit is shut-down and exposed to subfreezing ambient temperatures, the basin water may freeze.

A remote sump located in a heated indoor area is a desirable method of freeze protection. Alternatively, basin heaters, electrical immersion heaters, steam coil, or hot water coil) can be used to maintain the basin water at a minimum temperature of 40°F. **In addition to protect the cold water basin, all exposed water piping including pump piping below the overflow level and makeup water lines should be traced with electrical heater tape and insulated.**

CAPACITY CONTROL

It is necessary to prevent the recirculating water from approaching freezing conditions when the unit is operating under load. Capacity control on centrifugal fan units may be achieved through fan cycling, capacity control dampers, the ENERGY-MISER® Fan System, or two-speed motors. Capacity control dampers offer the greatest protection and should be used for close temperature control. Capacity control on axial fan units (VC2 only) may be achieved by fan cycling or two-speed fan motors.

Warning: Rapid on-off cycling can cause the fan motor to overheat. It is recommended that controls be set to allow a maximum of six-off cycles per hour.

Multiple fan motors serving a single coil, fill section, or fan section must be cycled simultaneously. This applies to models VT1-478 through VT1-600, VF1-216, VF1-432, VC1-540 through 804, VC1-1158-1608, and VC2-319 through 1774.

Units with two-speed motors should have a 15-second time delay during switch down from high to low speed to avoid overloads on the low speed windings of the motor. Units with the ENERGY-MISER® Fan System should also have a 15-second time delay during the switch down from high to low speed to avoid overloads on the lower horsepower motor.

Please note that capacity control dampers allow the unit to operate longer and with closer control than the ENERGY-MISER® Fan System, two-speed motor, and/or fan cycling. **The use of a modulating spray water bypass is not a recommended method of capacity control.**

Variable Frequency Drives

Motors: Applications employing variable frequency drives (VFDs) for fan motor control must use inverter duty electric motors built in compliance with NEMA Standard MG.1, Part 31. **The standard fan motors normally furnished with B.A.C. products are not intended for this duty and will not be warranted if so applied.**

Warning: When the fan speed of a Series V Closed Circuit Cooling Tower or Evaporative Condenser is to be changed from the factory set speed, including the use of a variable speed control device, steps must be taken to avoid operating at or near the fan's "critical speed" with resulting excessive vibration and stresses and the risk of personal injury and/or property damage. Consult with your local B.A.C. Representative on any application utilizing variable speed control to determine whether any critical speeds may be encountered and if any motor modifications may be required.

Recommended Operating Speeds: For optimum system performance and equipment longevity, fan motors should not be operated below 25% of full speed, nor within 10% of any unit resonant frequencies. Contact your local B.A.C. Representative for this information.

WARNING: Before performing any maintenance or inspection, make certain all electric power has been disconnected and locked in the off position.

Maximum Allowable Wire Runs: The VFD should be located as close as possible to the inverter duty motor. Depending on the style, operating voltage, and switching frequency, the maximum recommended length of wire can range from 20 to 200 feet. Consult the inverter manufacturer to determine the maximum allowable wire lengths for your application.

PROTECTION AGAINST COIL FREEZING (MODELS VF1 AND VFL ONLY)

The best protection against coil freeze-up is the use of an antifreeze solution. An industrial grade inhibited ethylene glycol or propylene glycol solution is recommended for most installations.

When an antifreeze solution is not possible, the system must be operated to meet **both** of the following conditions.

1. Maintain the minimum recommended flow through the coil at all times (see Table 5 below).
2. Maintain a heat load on the circulating fluid so that the temperature of the fluid leaving the coil will not fall below 50°F.

TABLE 5. VF1 and VFL Minimum Coil Flow Requirements

Model No.	Minimum Coil Flow (GPM)
VF1-009, VF1-018, VF1-027, VF1-036	50
VF1-048	75
VF1-072	100
VF1-096, VF1-144N	125
VF1-144, VF1-216N	200
VF1-192, VF1-288N	250
VF1-288, VF1-432	400
VFL-012 thru VFL-048	65
VFL-072 thru VFL-096	125

If the process load is extremely light or shut off, it may be necessary to apply an auxiliary heat load to the circulating fluid to maintain the fluid at 50°F when freezing conditions exist.*

Draining the coil is not recommended as a normal method of freeze protection. Frequent draining promotes corrosion inside the coil tube. However, draining is acceptable as an emergency method of freeze protection if the coil is not protected by an antifreeze solution. The local B.A.C. Representative should be consulted for guidelines on the installation of an emergency coil drain system.

**For evaporative chilling applications only, the leaving fluid temperature can be maintained as low as 45°F with glycol solutions. Consult the local B.A.C. Representative for necessary precaution.*

Water Treatment

CORROSION AND SCALE CONTROL

In Evaporative Cooling Products, cooling is accomplished by the evaporation of a portion of the process water as it flows through the unit. As this water evaporates, the impurities originally present remain in the recirculating water. The concentration of the dissolved solids increases rapidly and can reach unacceptable levels. In addition, airborne impurities are often introduced into the recirculating water, intensifying the problem. If these impurities and contaminants are not effectively controlled, they can cause scaling, corrosion, and sludge accumulations which reduce heat transfer efficiency and increase system operating costs.

The degree to which dissolved solids and other impurities build up in the re-circulating water may be defined as the cycles of concentration. Specifically, cycles of concentration is the ratio of dissolved solids (for example – total dissolved solids (TDS), chlorides, and sulfates) in the recirculating water to dissolved solids in the make-up water. **For optimal heat transfer efficiency and maximum equipment life, the cycles of concentration should be controlled such that the re-circulating water is maintained within the guidelines list below.**

Recirculated Water Quality Guidelines

	BALTIBOND® Corrosion Protection System*	Galvanized Steel
pH	6.5 to 9.0	7.0 to 9.0†
Hardness as CaCO ₃	30 to 500 ppm	30 to 500 ppm
Alkalinity as CaCO ₃	500 ppm max.	500 ppm max.
Total Dissolved Solids	1200 ppm max.	1000 ppm max.
Chlorides	250 ppm max.	125 ppm max.

† Units having galvanized steel construction and a circulating water pH of 8.3 or higher will require periodic passivation of the galvanized steel to prevent “white rust,” the accumulation of white, waxy, non-protective zinc corrosion products on galvanized steel surfaces.

* Closed Circuit Cooling Towers and Evaporative Condensers with BALTIBOND® Corrosion Protection System and hot-dip galvanized coils must use the water quality guidelines for galvanized steel units.

In order to control the cycles of concentration such that the above guidelines are maintained, it will be necessary to “bleed” or “blowdown” a small amount of recirculating water from the system. This “bleed” water is replenished with fresh make-up water, thereby limiting the build-up of impurities.

Typically the bleed is accomplished automatically through a solenoid valve controlled by a conductivity meter. **The conductivity meter set point is the water conductivity at the desired cycles of concentration and should be determined by a competent water treatment expert.** (Note: The solenoid valve and conductivity meter must be supplied by others.) Alternatively, a bleed line with a valve can be used to continuously bleed from the system. In this arrangement, the rate of bleed

can be adjusted using the valve in the bleed line and measured by filling a container of known volume while noting the time period. **The bleed rate and water quality should be periodically checked to ensure that adequate control of the water quality is being maintained.**

The required continuous bleed rate may be calculated by the formula,

$$\text{Bleed Rate} = \frac{\text{Evaporation Rate}}{\text{Number of Cycles of Concentration} - 1}$$

The evaporation rate can be determined by one of the following:

1. The evaporation rate is approximately 2 GPM per 1 million BTU/HR of heat rejection.
2. The evaporation rate is approximately 3 GPM per 100 tons of refrigeration.
3. Evaporation Rate = Water Flow Rate x Range x .001

Example: At a flow rate of 900 GPM and a cooling range of 10°F, the evaporation rate is 9 GPM (900 GPM x 10°F x .001 = 9 GPM).

Note: For Closed Circuit Cooling Towers, the flow rate to be used in this calculation is the flow through the coil.

Note: The bleed line must be furnished by others on VTO, VT1 and VTL cooling tower models.

If the site conditions are such that constant bleed-off will not control scale or corrosion and maintain the water quality within the guidelines, chemical treatment may be necessary. If a chemical treatment program is used, it must meet the following requirements:

1. The chemicals must be compatible with the unit construction (zinc-coated) steel as well as all other materials used in the system (pipe, heat exchanger, etc.)
2. **Chemicals to inhibit scale and corrosion should be added to the re-circulating water by an automatic feed system on a continuously metered basis.** This will prevent localized high concentrations of chemicals, which may cause corrosion. It is recommended the chemicals be fed into the system at the discharge of the recirculating pump on open cooling loops. **They must not be batch fed directly into the cold water basin.** For Series V coil products, chemicals should be metered into the recirculating water over the coil.
3. **Acid water treatment is not recommended unless the unit(s) have been furnished with the BALTIBOND® Corrosion Protection System or is constructed of Type 304 stainless steel - in which cases acid treatment can be used provided the requirements of paragraph 1 and 2 above are maintained.**

SYSTEM CLEANING

Closed Circuit Cooling Towers

With proper precautions, alkaline solution used to clean condenser water systems prior to start-up may be circulated through a Series V or Low Profile Series V Closed Circuit Cooling Tower.

The necessary precautions include:

1. Limit the duration of the cleaning to one, or at the most, two days.
2. The temperature of the solution should never exceed 100°F.
3. The maximum concentration of chemicals in the circulation solution should not exceed any of the following:

5% Sodium Hydroxide
5% Sodium Metasilicate
2% Sodium Carbonate
2% Tetra Sodium Pyrophosphate
0.5% Trisodium Phosphate
0.5% Sodium Nitrate
5-10% Butyl Cellulose

Evaporative Condensers

The installation and manufacturing processes commonly used for field-assembled steel-piped refrigeration systems leave weld byproducts inside coils and connecting piping. It is common practice to install filters and/or strainers that remove contaminants during initial system operation. Shortly after system startup, the filters and/or strainers should be cleaned or replaced.

Biological Control

Bleed-off with or without chemical treatment for scale and corrosion control is not adequate for control of biological contamination. The growth of algae, slimes and other microorganisms, if unchecked, will reduce system efficiency and may contribute to the growth of potentially harmful microorganisms, including Legionella, in the recirculating water system.

Accordingly, **a biocide treatment program specifically designed to address biological control should be initiated when the system is first filled with water and administered on a regular basis thereafter in accordance with the supplier's instructions.** Liquid biocides may be added to the basin of the cooling unit in dilute form. If a solid form of biocide is used, it should be added to the system via a pot feeder. **If ozone water treatment is used, ozone concentrations should not exceed 3-4 ppm in order to ensure maximum equipment life.**

B.A.C. offers a simple, easily applied, low maintenance form of biological control, the IOBIO: Bacteria, Slime and Algae Control. The control is easy to use and requires little maintenance. By delivering low concentrations of iodine through the make-up water line, the IOBIO: Control automatically controls unwanted microbiological contaminants in the open water system. Contact your local B.A.C. Representative for more information.

START-UP FOLLOWING A SHUT-DOWN PERIOD
To minimize the risk from biological contamination following a shut-down period, it is recommended that the entire system (evaporative cooling equipment, system piping, heat exchangers, etc.) be drained when the system is to be shut-down for more than three days. To resume operation of a drained system, clean all debris, such as leaves and dirt from the cooling tower and re-fill the system with fresh water. While operating the circulating pump(s) and prior to operating the unit fans, execute one of the following two alternative biocide treatment programs:

1. Resume treatment with the biocide, which had been used prior to shut-down. Maintain the maximum recom-

mended biocide residual (for the specific biocide) for a sufficient period of time (residual and time will vary with the biocide) as recommended by the water treatment supplier to bring the system under good biological control.

2. Check the pH of the circulating water and, if necessary, adjust it to 7.0 to 7.6. Then treat the system with sodium hypochlorite to maintain a level of 4 to 5 mg/l (ppm) free chlorine (as Cl₂) over a six (6) hour period. Test kits that can be used to measure the free residual of chlorine are commercially available.

When it is not practical to drain the system during shut-down periods, a by-pass line with shut-off valves should be installed to permit the cooling water to be circulated throughout the system, including the unit basin, while bypassing the heat transfer section. Then, after each shut-down of three (3) days or more, the system should be treated prior to restarting the unit using one of the two methods described above.

However, while circulating the treated cooling tower water through the entire system, the cooling tower fill should be by-passed and the tower fans kept inoperative. After the biocide residual has been maintained at the required level for at least six (6) hours, the water can be directed over the fill and the tower returned to service. The standard water treatment program (including the biological treatment) should be resumed at this time.

For specific recommendations on treatment for scale, corrosion, or biological control, consult a qualified water treatment consultant.

COIL CLEANING

Both the inside and outside of the heat exchange coil may require occasional cleaning. The chemicals used must be compatible with the materials being treated (for example - standard coil: outside of the coil is galvanized steel; inside coil is black carbon steel). **For specific recommendations on coil cleaning, consult a qualified water treatment consultant.**

Factory Authorized Parts

Baltimore Aircoil Company maintains a stock of replacement parts at each of its manufacturing facilities. Shipment of these parts is normally within four days after receipt of an order. In emergency situations, shipment can usually be made within twenty-four hours. To order factory authorized parts, contact your local B.A.C. Representative. Be sure to include the unit serial number when ordering any parts.

To facilitate servicing the unit, it is suggested that the following parts be carried on hand:

Make-Up Float Ball
Valve Seat for Make-Up Valve
Fan Shaft Bearings
Fan Wheel
Fan Belt(s)
Fan Shaft
Spray Nozzles and Grommets
Spray Distribution Branch Grommet
Access Door Gasket



Baltimore Aircoil

P.O. Box 7322, Baltimore, Maryland 21227
410-799-6200 Fax 410-799-6416
www.BaltimoreAircoil.com
email: info@BaltimoreAircoil.com

ONE OF THE **Amsted**
INDUSTRIES