



ADDENDUM 4
City of Newport News
IFB#2011-3736-2005

January 28, 2011

Purchasing Department, Office of the Purchasing Director
4th Floor, City Hall, 2400 Washington Avenue
Newport News, VA 23607
Phone: (757) 926-8031/ Fax: (757) 926-8038
<http://www.nngov.com/purchasing>

STONEY RUN COMMUNITY CENTER PHASE II

Sealed bids subject to the conditions and instructions contained herein, will be received at the above office of the Purchasing Director, 4th Floor, City Hall, 2400 Washington Avenue, Newport News, Virginia 23607, until the time and date shown below (local prevailing time), for furnishing the items or services described in the bid.

It is agreed and understood this page and any following pages will constitute addendum 4, and shall be made part of the IFB document. Acknowledgement, showing receipt and acceptance of the changes is to be returned in the manner specified.

This published addendum consists of questions, answers, changes to specifications and drawings.

Please Note:

Replace pages B-2 and B-3, C-3 and C-4 with pages B-2 and B-3, C-3 and C-4 included with this addendum. See additional document changes and additions as noted on the following pages.

The Bid Due Date has been extended to 3:00 p.m., February 8, 2011.

Shari D. Colvin

Contract Officer: _____

Shari D. Colvin, CPPB, Deputy Director, scolvin@nngov.com and Brenda L. Vines, Assistant Buyer, bvines@nngov.com

Company Name: _____

Address: _____

City/State/Zip: _____

Telephone: _____ FAX No.: _____

E-mail: _____

Print Name: _____ Title: _____

Signature: _____ Date: _____

This form must be signed. All signatures must be original and not photocopies.

Stoney Run Community Center – Phase II

- Question 1: Typically a “Demolition Drawing” is produced to indicate the extent of the site demolition work required for the project. Since there was a previous contract demolition phase for this project, can a drawing be provided to indicate what the demolition requirements for this contract will be?
- Answer 1: Bidders should assume that previous construction was completely removed. Demolition for this phase includes all demolition required to produce a structurally sound result as shown in the contract documents.
- Question 2: There are projection screens indicated on drawings A6.01 & A6.02. Are these screens part of the contract? If so, please provide specification requirements.
- Answer 2: The projection screens are part of the contractor-provided audio-visual equipment specified in Specification Section 16810.
- Question 3: The Outdoor Play Area calls for a Poured-in-Place Protective Surface material. What will be the substrate for this material? Concrete slab, stone base, etc?
- Answer 3: The substrate for the play area surface is a four-inch thick concrete slab meeting the requirements for sidewalks in the project.
- Question 4: The Ceiling Notes on Drawing A6.03 call for plaster ceilings in some areas. It is not clear where the plaster ceilings are to go. There is also no specification for plaster ceilings?
- Answer 4: There are no plaster ceilings in the project.
- Question 5: Is there a contractual requirement for providing a temporary chain link fence around the building site during construction or is this a Contractor option?
- Answer 5: Security of the building and the contractor's materials and equipment is the contractor's responsibility. Exact methods are his option.
- Question 6: Are all sidewalks to receive welded wire mesh as indicated on Drawing C6.0?
- Answer 6: The sidewalk detail on sheet C6.0 is for “Monolithic Concrete Curb and Sidewalk” which is used adjacent to vehicular areas. There is a separate detail on sheet C6.1 for normal concrete sidewalk. Welded wire mesh is only required for monolithic curb and sidewalk pours adjacent to vehicular areas.
- Question 7: In the footing undercut detail on Drawing S1.02, the bottom of the crushed stone backfill is indicated to be at -3'-0” below the finished floor elevation. The bottom of footings CF8.0 & CF10.0 are at or

Stoney Run Community Center – Phase II

below the -3'-0" elevation. Will crushed stone backfill be required under those footings and if so, how thick do you require it to be?

Answer 7: Comply with the recommendations of the soils report included in the Project Manual. If the bottom of the footing exceeds three feet below finished floor, no crushed stone would be required if the undercut depth is approved by geotechnical engineer (this will be established in the field by special inspector/geotech).

Question 8: Specification 03300 Part 2 products indicate reinforcing bars and epoxy coated Joint Dowel Bars; same Specification Sections Paragraph 3.4 Steel Reinforcement refers to epoxy coated steel reinforcement, please verify whether Steel Reinforcement Bars or Joint Dowel Bars shall be epoxy coated?

Answer 8: An epoxy coating is not required for any of the steel reinforcing used in this project.

Question 9: Please specify what room #'s shall receive Slip Resistive Finish as per Specification Section 03300 Paragraph 3.9, G?

Answer 9: The type of slip resistant finish described in the cited paragraph will not be used in this project.

Question 10: Please specify what Room #'s shall receive Dry Shake Hardener Finish Section 03300, Paragraph 3.9, H?

Answer 10: Use the dry shake hardener on the concrete floors of mechanical room 135, storage room 167, and vestibule 168.

Question 11: Per Specification Section 01100 Paragraph 1.7 Permits and Fees it is indicated the contractor is to pay for Temporary Electrical Connection, Erosion and Sedimentation Fees and Bonds and Right of Way Permits; Please specify the amount of the cost for the Erosion Control and Sedimentation Fees and the Right of Way Permits.

Answer 11: Contractor to contact City of Newport News, Department of Engineering for the cost for Erosion and Sedimentation Fees and Right of Way Permits.

Question 12: Reference Specification Section 01230 3.1.B and 3.1.C. Alternates 2 and 3 both indicate the deletion of "all construction shown in sheets W1.01 through W1.04." This will make a double deduction for only one scope of work. Is it intended that the scope of work shown on sheets W1.01 through W1.04 be deducted from both Alternate #2 and Alternate #3? Please clarify.

Answer 12: Both Alternate No. 2 and Alternate No. 3 include deleting the water feature. Alternate No. 2 may be chosen by the Owner, and Alternate No. 3 may be chosen by the Owner, but the Owner will not choose both.

Stoney Run Community Center – Phase II

- Question 13: Reference Specification Section 01230 3.1.B. Alternate #3 provides for a different overall site layout; however, the drawings to be used in lieu of the base bid drawings do not have corresponding Landscape and Irrigation layouts. Please provide Landscape and Irrigation Layouts to be used for Alternate #3.
- Answer 13: For bidding purposes, ignore the landscaping for Alternate No. 3. If this alternate is taken, new landscape and irrigation layouts will be developed, and a new cost for those items will be negotiated with the contractor.
- Question 14: Reference Sheet C1.2. It is understood that the Site Demolition in areas noted as “Phase 2B” and “Phase 2C” will be performed under a separate contract. In what state will these parcels be left after demolition? For example, will the subgrade be filled and graded to the correct elevation for the proposed parking areas? Please advise.
- Answer 14: Demolition of the areas identified in the civil sheets as "Phase 2B" and "Phase 2C" are included in the project. A specification section for structure demolition is provided by addendum.
- Question 15: Sheet C2.0 shows a faint indication of an existing automobile dealership. After attending the site visit, this structure has clearly been demolished. It is unclear if the structural foundation for this building was also removed at the time of demolition. Please clarify.
- Answer 15: Bidders should assume that demolition included all construction, including the structural foundations.
- Question 16: Reference Sheet C1.0 Utilities Note #6 and sheet C1.1 City of Newport News General Notes #1. Please confirm that “Any and all utilities and/or obstructions (power poles, telephone pedestals, guy wires, water meter, etc.) that are required to be relocated or adjusted due to construction shall be done so at the Owner/Developers expense.
- Answer 16: Utilities, and items owned by utility companies, that are required to be moved will be moved at the Owner's expense.
- Question 17: Reference Sheet A7.01. The enlarged floor plan for the Single Occupancy Toilet indicates “RSND,” however; the Toilet Accessories Legend does not provide a description. Is this item(s) cost to be included in the bid? If so, please provide product information.
- Answer 17: "RSND" indicated a recessed sanitary napkin disposal. This item has been deleted from the contract.
- Question 18: Specification 05120, Section 2.3 “Primer” lists 4 different types. Which one, if any is required for structural steel? Please advise.
- Answer 18: Use 2.3.D: fabricator's standard lead- and chromate-free, nonasphaltic, rust-inhibiting primer.

Stoney Run Community Center – Phase II

- Question 19: Specification 05310, Section 1.4.B indicated “Electrified Cellular Floor Deck.” Is this reference in error since there is only “roof deck” and cellular is not indicated? Please advise.
- Answer 19: No cellular floor deck or electrified cellular floor deck will be used in the project.
- Question 20: Specification Section 07160 Bituminous Dampproofing, part 3.4 A talked about below-grade dampproofing. However, the plans (wall sections) don’t show below-grade D.P. Any clarification is appreciated.
- Answer 20: All dampproofing will be on CMU in the masonry wall cavities, above grade. There is no below-grade dampproofing included in the project.
- Question 21: Please confirm that the city may accept either Alternate #2 or Alternate #3, but not both (the water feature is deleted in both alternates).
- Answer 21: Correct. See Answer 12.
- Question 22: Spec 13141 Water Feature Equipment, 2.2 Underground Mechanical Vault states, “Prefabricated fiberglass”. On Drawing W1.04 the 11x17 ARC Drawing 13 of 13 shows it as a concrete vault on detail 2. Go by the specs?
- Answer 22: All underground mechanical vaults associated with the water feature must be concrete.
- Question 23: Specification 02221, 1.2 Summary lists “Demolition...of site improvements”, “Removing below-grade construction”, “Disconnecting, removing site utilities”. There is no Demolition Drawing and it is difficult to read the existing notations on the civil drawings where they have been overlaid with new construction. Please provide a Site Demolition Drawing and/or quantify these requirements.
- Answer 23: See the answers to questions 1 and 15.
- Question 24: Should Landscaping and Irrigation be part of deductive Alternate #3?
- Answer 24: See Answer 13.
- Question 25: The Landfill Gas Pipeline is shown on C4.0 & GP-1, and Utilities Note 9 on C1.0 mentions Gas Company requirements for trenching, but P1.01 at the Service Yard shows “Land Fill Gas supplied by others”. Please clarify if the Landfill Gas Pipeline on C4.0 & GP-1 is to be included in the bid?
- Answer 25: The landfill gas pipeline on C4.0 & GP-1 is included in the project.

Stoney Run Community Center – Phase II

- Question 26: Detail 6 on A4.15 states, “anchor fence posts to bond beam”. Specs list setting posts into sleeves as well as anchor bolt/flange systems. Is either method acceptable?
- Answer 26: Both anchoring methods are acceptable, subject to approval during the shop drawing review process.
- Question 27: Detail 2 on A2.01 shows the Service Yard vehicle gate having a filler panel or wire mesh. Detail 7 on A2.02 does not. Specs do not mention any filler panel or wire mesh. Please provide filler panel or wire mesh requirements if such is required.
- Answer 27: There will not be any filler panel or wire mesh in the vehicle gate to the service yard.
- Question 28: Two of the colors that are specified for Corian work surfaces have been discontinued. Please advise.
- Answer 28: After award of contract, two colors from the same cost groups will be selected.
- Question 29: In regards to the Addendum #2 addition of paragraph 5 to 15900.2.23, could we get clarification? Is the intent to use separate kWh and ammeter on the chiller and on each supply and exhaust fan for the RAHU's (total quantity 7 kWh and ammeters). In addition, is the intent to read kWh and amperage (current) on each of the gas boilers?
- Answer 29: Provide separate metering capabilities for each RAHU, Chiller and Boiler to illustrate KWh and Amps for each piece of equipment in operation. Tie meters to the DDC system for purposes of monitoring and trending.
- Question 30: The Plumbing plans do not address the roof and overflow drains shown on A-301 Roof Plan at Storage Room 167 roof.
- Answer 30: Sketches are given by addendum to address these roof drains.
- Question 31: Specifications Section 02810 Irrigation Systems, paragraph 1.7.A.1 Extra Material, requires additional spray sprinklers. There are 2 types of spray sprinkler heads and 3 types of rotor sprinkler heads in the irrigation system. Please define what is meant by “spray” sprinklers. Is the “spray” sprinkler wording meaning only the 2 types of spray sprinkler heads (excluding the rotor sprinkler heads) or does it mean both the spray sprinkler and the rotor sprinkler heads?
- Answer 31: Provide extra material not only for each type of spray sprinkler head, but for each type of rotor sprinkler heads as well.
- Question 32: Specifications Section 02810 Irrigation Systems, 3.2. Piping Applications, paragraph A requires installing components having pressure rating equal to or greater than system operating pressure. All piping on the irrigation plan is listed as schedule 40 PVC. Normal

Stoney Run Community Center – Phase II

practice for irrigation systems is PR200 PVC. PR200 PVC pipe is rated for more than double the system operating pressure on city water pressure and would conserve funds for the overall project cost. Would PR200 PVC be considered for the irrigation system piping since it meets the specification 3.2A?

Answer 32: Comply with the schedule 40 requirement of the drawing.

Question 33: Specifications Section 02810 Irrigation Systems, 3.3 Piping Installation, paragraph B requires installing piping at a minimum uniform slope of 0.5 percent down toward drain valves. There are no drain valves indicated on the irrigation plan provided.

Answer 33: Since drain valves are not indicated, the downward slope is not required.

Question 34: Specifications Section 02810 Irrigation Systems, 3.3 Piping Installation, paragraph J requires water regulators with shutoff valves and strainers. There are no specifications for the operating characteristics of the regulators and strainer. The irrigation plan does not include the water regulators and strainer location.

Answer 34: Disregard paragraph J. No regulators or strainers are required.

Question 35: There is no mention in the notes or on any plan sheet about the removal of the existing buildings and slabs on the property under eminent domain proceedings. Will the City remove these buildings and slabs when the case is settled?

Answer 35: The removal of the existing construction is included in the Base Bid, and deleting that demolition is addressed in bid alternates included by addendum. If the cases are not settled at the time of signing the contract, the alternates will be taken, and the City will initiate removal when the appropriate time comes.

Question 36: Will the City supply topsoil for the seeded areas?

Answer 36: No.

Question 37: Will the City accept the excavated material at the old landfill?

Answer 37: No.

Question 38: Where is the monolithic curb & sidewalk (detail on sheet C6.0) with 8” stone located? Do you want 8” stone under all the sidewalk?

Answer 38: The monolithic curb & sidewalk is used only adjacent to paved vehicular areas. Other sidewalks are not required to have eight inches of stone under them, just compacted subgrade.

Question 39: LFG pipeline(Sheet 2 of 2)detail 7/2-2 shows ‘Pipeline Marker’— how many and where located?

Stoney Run Community Center – Phase II

- Answer 39: Refer to the LFG specifications, added by addendum.
- Question 40: LFG pipeline(Sheet 2 of 2) detail 1/1-2 shows pipe bedding—what bedding material do you want under this HDPE pipe?
- Answer 40: Refer to the LFG specifications, added by addendum.
- Question 41: In the new building footprint, can the existing stone be left in place?
- Answer 41: The existing stone may be used only if specifically approved by the owner's geotechnical engineer. For bidding purposes, the bidder should not assume that the existing stone can be used.
- Question 42: At the front door, can the bollards be placed behind the continuous truncated domes?
- Answer 42: No.
- Question 43: Specification 10651 Operable Panel Partitions, paragraph 2.2B states paired panels, however floor plan shows single panels with remote stack. Please clarify. In the same section, paragraph 2.6A calls for pocket door, however, none is shown on floor plan. Please clarify.
- Answer 43: Use a single-panel partition system, with Modernfold model 931 as the Basis of Design. No storage pocket door will be required.
- Question 44: Can a scroll compressor air cooled chiller be used in lieu of a screw compressor air cooled chiller if it meets all the other performance criteria?
- Answer 44: No.
- Question 45: With regards to closet storage shelving throughout the building; would white melamine particle board be an acceptable alternative to plywood covered with white plastic laminate (white vinyl edging on all visible edges)?
- Answer 45: No.
- Question 46: Please specify the material and color finish for countertop in Computer Room 126.
- Answer 46: The countertop in Computer Room 126 will be solid surfacing. The color will be chosen from the same price group as SS-1.
- Question 47: I cannot find a specification section for the 6” LFG pipeline from the existing landfill to the proposed building. Please advise.
- Answer 47: LFG pipeline specifications are provided by addendum.
- Question 48: What is the pressure in the pipeline going into the pressure regulator at the building?

Stoney Run Community Center – Phase II

Answer 48: The pressure was calculated to be approximately 7 psig in the pipeline design.

Question #49: I have a question regarding the alternate LED lighting design listed in the bid documents. It appears the LED lighting layout does not meet city standard lighting requirements. It also appears there is a walkway that is missing that runs across the rec center that would also require lighting. Are there any exceptions being made in regards to the LED plan, or will the LED lighting need to meet the same city requirements required on other projects (0.9 foot-candle minimum on paved areas, 2.2 foot-candles min on sidewalks, etc.)?

Answer #49: The LED alternate lighting design layout will need to meet the city standards for lighting.

Question #50: Do you have a timeline on the completion of this project?

Answer #50: As stated on the Bid Form, page B-6 & the Contract page C-2, the contractor shall substantially complete the project within four hundred eighty-six (486) calendar days from the date of Notice To Proceed.

CHANGES TO THE SPECIFICATIONS

TABLE OF CONTENTS

ADD: The following to the list of sections in Division 2:
Section 02220 LFG Pipeline Trenching and Backfilling
Section 02221 Structure Demolition

ADD: The following to the list of sections in Division 15:
Section 15050 LFG Pipeline Underground Pipe and Accessories
Section 15190 LFG Pipeline Aboveground Pipe and Accessories

ADD: The following to the list of sections in Division 16:
Section 16810 Audio And Video Equipment

SECTION 01230 ALTERNATES, PAGE 01230-2

CHANGE: The wording of Alternate No. 1 to the following:

A. Alternate No. 1: Provide an “add” or “deduct” cost for the furnishing and installation of LED site lighting fixtures. In lieu of the site lighting fixtures and layout shown on drawing Sheet E5.01, provide the Beta LED fixtures with poles, using a layout similar to that indicated on the Luminaire Schedule/Photometric shown on Sheet E5.03. In the design, include the water feature, and the sidewalk on the east side of the building. The Beta fixture is the Basis of Design. LED fixtures shall comply with the performance specifications included after this Section for each fixture type. Each bidder shall submit with his bid the LED Fixture Quote Form for each fixture type. Successful bidder shall submit photometric point-by-point lighting layout included with his shop drawings, confirming compliance with City of Newport News General Lighting Standards.

SECTION 01230 ALTERNATES, PAGE 01230-2

ADD: The following Alternate No. 4:

D. Alternate No. 4: Provide a cost to be deducted from the Base Bid to omit all demolition work located within the area denoted as "Phase 2B" in the civil drawings, and to leave the area untouched.

SECTION 01230 ALTERNATES, PAGE 01230-2

ADD: The following Alternate No. 5:

- E. Alternate No. 5: Provide a cost to be deducted from the Base Bid to omit all demolition work located within the area denoted as "Phase 2C" in the civil drawings, and to leave the area untouched.

SECTION 02220 LFG PIPELINE TRENCHING AND BACKFILLING

ADD: Section, included with this Addendum, in its entirety.

SECTION 02221 STRUCTURE DEMOLITION

ADD: Section, included with this Addendum, in its entirety.

SECTION 10651 OPERABLE PANEL PARTITIONS, PAGE 10651-4

CHANGE: Basis of design product in Paragraph 2.2.A.1 from "Acoustiseal model 932" to "Acoustiseal model 931."

CHANGE: Panel operation in Paragraph 2.2.B from "Manually operated, paired panels" to "Manually operated, single panels."

SECTION 10651 OPERABLE PANEL PARTITIONS, PAGE 10651-6

DELETE: Paragraph 2.6 in its entirety.

SECTION 15050 LFG PIPELINE UNDERGROUND PIPE AND ACCESSORIES

ADD: Section, included with this Addendum, in its entirety.

SECTION 15190 LFG PIPELINE ABOVEGROUND PIPE AND ACCESSORIES

ADD: Section, included with this Addendum, in its entirety.

ITEM NO. 11 SECTION 15800 HEATING, VENTILATING AND AIR CONDITIONING, PAGE 15800-5

REMOVE: "McQuay" from the list of acceptable manufacturers in Paragraph 2.2.A.1.

ITEM NO. 12 SECTION 15800 HEATING, VENTILATING AND AIR CONDITIONING, PAGE 15800-9

REMOVE: "McQuay" from the list of acceptable manufacturers in Paragraph 2.3.A.1.

ITEM NO. 13 SECTION 15800 HEATING, VENTILATING AND AIR CONDITIONING, PAGE 15800-22

REMOVE: “McQuay” from the list of acceptable manufacturers in Paragraph 2.5.A.1.

ITEM NO. 14 SECTION 15800 HEATING, VENTILATING AND AIR CONDITIONING, PAGE 15800-23

REMOVE: “McQuay” from the list of acceptable manufacturers in Paragraph 2.5.B.1.

REMOVE: “McQuay” from the list of acceptable manufacturers in Paragraph 2.5.C.1.

ITEM NO. 15 SECTION 16810 AUDIO AND VIDEO EQUIPMENT, PAGE 16810-7

CHANGE: Speakers in the 118 Outdoor Play Area from "EV Full Range Speakers ZX1-i 100t B" to "Technomad Weather-proof Full Range Speaker Paris 616T/PN:681."

CHANGE: Connection covers in the 118 Outdoor Play Area from "EV Connection Cover ZX1-i" to "Technomad Wall Mount PN:512."

ITEM NO. 16 SECTION A BID. PAGE B-2 & B-3

CHANGE: Alternate #4 & Alternate #5 to be added to Bid Form. Replace Sheets B-2 & B-3 with attached revised Sheets B-2 & B-3.

ITEM NO. 17 SECTION B CONTRACT, PAGE C-3 & C-4

CHANGE: Alternate #4 & Alternate #5 to be added to Bid Form. Replace sheets C-3 & C-4 with attached revised Sheets C-3 & C-4.

CHANGES TO THE DRAWINGS

ITEM NO. 18 SHEET C1.0, NOTES

DELETE: Note number 6 under "Utilities."

ITEM NO. 19 SHEET C4.0, UTILITY PLAN

ADD: Connection for storage room roof drainage, as shown in Sketch SK-C1, included with this Addendum.

ITEM NO. 20 SHEET SHEET A4.15, WALL SECTION 6/A4.15

CLARIFICATION: The multi-layered horizontal surface adjacent to the wall consists of outdoor play area surfacing on a four-inch-thick concrete slab, on compacted subgrade.

ITEM NO. 21 SHEET SHEET A7.01, TYPICAL TOILET PLANS

DELETE: All references to "RSND" in the detail plans for Accessible Stall, Ambulatory Stall, Standard Stall, and Single Occupancy Toilet.

ITEM NO. 22 SHEET SHEET SP1.02, PARTIAL FLOOR PLAN – AREA B - SPRINKLER

ADD: Normal hazard occupancy designation for Storage Room 167, as indicated in Sketch Sk-SP1, incl

SECTION 02220 – LFG PIPELINE TRENCHING AND BACKFILLING

PART 1 GENERAL

1.01 DESCRIPTION OF WORK

- A. The Work in this Section includes all labor, materials, equipment, permitting, testing, and incidentals required to perform all excavation, backfilling, compaction, and grading, required for the installation of the LFG pipeline, pipeline cleanouts, boring and jacking pits, and appurtenances, as shown on the Construction Drawings and specified herein.
- B. CONTRACTOR shall provide the necessary materials to allow traffic to safely cross over open trenches within road crossings.

1.02 PROJECT CONDITIONS

- A. Existing Structures and Utilities: Locate existing surface and underground structure and utilities in the responsibility of the CONTRACTOR.
- B. CONTRACTOR shall explore ahead of the Work to determine the actual location and depth of all structures and utilities and physically locate utilities which are crossed by the LFG pipeline. They shall be supported and protected from injury by the CONTRACTOR. If they are broken or injured, they shall be restored immediately by the CONTRACTOR at his expense.
- C. Sufficient numbers of shallow test holes shall be made along the route of the LFG pipeline by the CONTRACTOR to field locate underground utilities along the pipeline route. The locations of the test holes shall be included on the final record drawings. As an option, CONTRACTOR may utilize a utility location service that employs ground penetrating radar or other indirect sensing methods.
- D. Use of Explosives: Use of explosives is not permitted without prior authorization of the OWNER and should only be considered if excavation cannot be accomplished using conventional earthmoving equipment. When use of explosives is necessary and approved by OWNER, the CONTRACTOR shall exercise the utmost care not to endanger life or property, including the pipeline work, and shall comply with Section 107.11 of VDOT Standard Specifications for Highway Construction.

- E. CONTRACTOR shall not disturb the geosynthetic components of the existing landfill cap and shall obtain limits of cap from City prior to excavation. Damage to geosynthetic components of the cap caused by CONTRACTOR operation shall be repaired by CONTRACTOR at no expense to City.

1.03 PROTECTION

- A. CONTRACTOR shall:
 - 1. Protect trees, shrubs, lawns, rock outcroppings and other features remaining as part of final landscaping.
 - 2. Repair damage to paved areas, fences, signs, markers, structures, pipes, bridges, embankments, vegetated areas, and other features that are caused by the construction operations.

PART 2 PRODUCTS

2.01 PIPE BEDDING MATERIAL

- A. Pipe Bedding material shall consist of granular, non-cohesive material classified as SW, SP, SM, SP-SM, SC, GW, GP, GM, or GP-GM in the Unified Soil Classification System (ASTM D 2487 – Classification of Soils for Engineering Purposes) and with maximum particle size of 2 inches in any dimension.
- B. Plasticity Index (PI) less than 4 as measured by ASTM D 4318 – Standard Test Method for Liquid Limit, Plastic Limit, and Plasticity Index of Soils.
- C. Shall not be saturated at time of placement and compactable to the specified relative compaction indicated herein.
- D. Shall be free of debris, waste, frozen material, vegetation, organic materials, roots and other deleterious matter.

2.02 GENERAL FILL

- A. General Fill material shall be free of stone, rock or gravel larger than two (2) inches in any dimension, debris, waste, frozen materials, vegetation, organic materials, roots, and other deleterious matter.
- B. Shall not be saturated at time of placement and compactable to the specified relative compaction indicated herein.
- C. Plasticity Index (PI) less than 30 and Liquid Limit (LL) less than 50 as measured by ASTM D 4318 – Standard Test Method for Liquid

Limit, Plastic Limit, and Plasticity Index of Soils, or as approved by ENGINEER.

- D. General fill material shall be used for backfilling and filling as shown on the Construction Drawings, including the pipeline trench, boring and jacking pits, cleanouts, and for other areas as approved by the ENGINEER

2.03 AGGREGATE

- A. Aggregate used for replacement and repair of base courses for roads, sidewalks, or other paved areas that are disturbed by pipeline and related construction activities shall meet the requirements specified in VDOT Standard Specifications for Highway Construction or as approved by ENGINEER.
- B. Aggregate shall conform to the gradation requirements for Aggregate No. 21A unless otherwise approved by ENGINEER.

2.04 CONCRETE

- A. Asphaltic concrete used for repair of asphalt paved roads, driveways and parking areas that are disturbed by pipeline installation and related construction activities shall conform to the requirements of Section 315 of VDOT Standard Specifications for Highway Construction or as approved by OWNER.
- B. Portland cement concrete used for the repair of roads, structures and driveways that are disturbed by pipeline installation and related construction activities shall conform to the requirements of Section 315 of VDOT Standard Specifications for Highway Construction or as approved by OWNER.

2.05 BURIED PIPE WARNING AND IDENTIFICATION TAPE

- A. Polyethylene plastic and metallic core or metallic-faced, acid-and alkali-resistant, warning tape manufactured specifically for warning and identification of buried utility lines. Provide tape on rolls, 3-inch minimum width, color-coded as specified for the intended utility, with warning and identification imprinted in bold black letters continuously over the entire tape length. Warning and identification to read, "CAUTION: PRESSURIZED UNDERGROUND GAS PIPELINE, City of Newport News 1-757-XXX-XXXX", or similar wording. Color and printing shall be permanent, unaffected by moisture or soil. Contact City for appropriate notification phone number.

2.06 PIPELINE MARKERS

- A. Pipeline markers shall be weather resistant. The post shall be polyethylene or approved equal by the ENGINEER. The marker shall be round and have an outside diameter of 3.5". Graphic shall be on two sides and shall read, "CAUTION: PRESSURIZED UNDERGROUND GAS PIPELINE, City of Newport News 1-757-XXX-XXXX", or similar wording. Color and printing shall be permanent, unaffected by moisture or soil. Contact City for appropriate notification phone number.

2.07 OTHER MATERIALS

- A. All other materials, not specifically described but required for proper completion of the Work, shall be selected by the CONTRACTOR and approved by the ENGINEER.

2.08 GROUT

- A. Use non shrink grout with a minimum strength of 3,000 psi at 3 days or equal material. Manufacturers and Products:
 1. Master Builders Co., Cleveland, OH; SET GROUT.
 2. Euclid Chemical Co., Cleveland, OH; NS Grout.
 3. Dayton Superior Corp., Miamisburg, OH; Sure-Grip High Performance Grout.
 4. ENGINEER or approved equal.

PART 3 EXECUTION

3.01 EXAMINATION

- A. Examine the areas and conditions under which Work of this Section will be performed. CONTRACTOR shall correct conditions detrimental to proper and timely completion of the Work.
- B. Grades

Pipes shall be laid so as to achieve the minimum cover and clearances indicated elsewhere and/or in the Drawings.
- C. Location of Pipelines
 1. The location of the proposed LFG pipeline is shown on the Construction Drawings.
 2. The final location of the LFG pipeline may be adjusted in the field by the CONTRACTOR due to conditions encountered, or to avoid conflicting with existing utilities.

3. CONTRACTOR shall notify OWNER and ENGINEER of any significant changes in the pipeline location, or depth, prior to construction.
4. Changes to horizontal alignment greater than 10 ft from alignment shown on drawings shall require approval by the ENGINEER.

3.02 PREPARATION

- A. CONTRACTOR shall establish and identify required lines, levels, contours, and datum locations.
- B. CONTRACTOR shall maintain benchmarks, monuments, and other reference points and re-establish if destroyed or damaged, at no cost to OWNER.

3.03 TRENCHING AND EXCAVATING

- A. Remove standing water, soft and compressible materials, and other materials that interfere with Work, prior to placing pipe bedding or general fill.
- B. Do not interfere within a 45-degree bearing splay of foundations.
- C. Correct over-excavated areas with general fill and compact replacement as specified for authorized excavation or replace with fill concrete, as directed at no additional expense to owner.
- D. Stockpile excavated material in area designated on-site and remove excess material not being used from the site.
- E. Trenches
 1. Trenches shall be dug so that the pipe can be laid and jointed properly. It shall be excavated only so far in advance of pipe laying as can be temporarily covered by the end of the work day.
 2. Trench Width: The excavation shall not be more than 2 feet wider at the bottom than the outside diameter of the pipe.
- F. Excavation within 24 inches of existing utilities shall be governed by the Technical Specifications of the respective utility and local, State, and Federal requirements. The CONTRACTOR shall obtain these Technical Specifications and follow the same at no extra cost.

3.04 PIPELINE MARKERS

- A. Pipeline markers shall be placed at each crossing of a public road and railroad. Place on each side of crossing, within 20 ft of crossing.
- B. Pipeline markers shall be placed every 500 feet along the LFG pipeline.

3.05 SHEETING AND BRACING

- A. General
 - 1. Sheeting and bracing of all excavations shall conform to the latest statutes of the Commonwealth of Virginia governing safety of workers in the construction industry. Any damage due to settlement because of failure to use sheeting or because of inadequate bracing, or through negligence or fault of the CONTRACTOR in any other manner, shall be repaired at the CONTRACTOR'S expense.
- B. Sheeting Requirements:
 - 1. Where excavations are made with vertical sides which require supporting, the sheeting and bracing shall be of sufficient strength to sustain the sides of the excavations and to prevent movement which could in any way injure the Work, or adjacent structures, or diminish the working space sufficiently to delay the Work. Special precautions shall be taken where there is additional pressure due to the presence of other structures.
 - 2. It shall be the CONTRACTOR'S responsibility to select sheeting and bracing of sufficient dimensions and strength to adequately support the sides of trenches and excavations. The CONTRACTOR shall submit details of the sheeting and bracing proposes for use to the ENGINEER for review.
 - 3. Timber sheeting shall conform in quality to select structural Douglas Fir lumber and shall be sound, live timber, free from sap, large checks, shakes, loose or decayed knots, worm holes, and other imperfections which may impair its strength or durability.
 - 4. Sheeting and bracing shall be removed before the completion of the Work, unless otherwise directed in writing by the ENGINEER. Sheeting which is left in place shall be cut off 18 inches below the original ground surface or as directed by the ENGINEER. Untreated wood will not be allowed to be left in place.

3.06 GENERAL BACKFILLING PROCEDURES

- A. Material shall be placed in a manner which will prevent distortion, damage to, or displacement of the pipe from its intended location. Pipe bedding material shall also be placed so that adequate support will be provided in the haunch support areas for the pipe. Voids or loose soils which are found to occur due to improper placement or compaction of materials will result in rejection of that portion of the pipe installation. Replacement of the materials will be at the CONTRACTOR'S expense.
- B. Employ a placement method that does not disturb or damage adjacent features.

3.07 PLACEMENT AND COMPACTION

- A. General:
 - 1. Place all backfill and fill materials in horizontal layers not more than 8 inches in loose depth for material compacted by heavy compaction equipment, and not more than 6 inches in loose depth for material compacted by hand-operated equipments. Thickness of layers may be increased or decreased provided the equipment and methods used are proven by field density testing to be capable of compacting thicker or thinner layers to specified densities and approved by the ENGINEER.
 - 2. Compact fill and backfill to the minimum percentage of density and within moisture contents specified for each area classification indicated.
 - 3. Each successive lift shall not be placed or compacted until the previous lift has been tested by the CONTRACTOR'S CQC testing service, and meets compaction requirements, or is observed and approved by the ENGINEER.
 - 4. Alternative compaction methods may be submitted to the ENGINEER for approval.
- B. Moisture Control: Where subgrade or fill materials must be moisture-conditioned before compaction:
 - 1. Apply water uniformly to surface of subgrade or fill materials, and work soil as necessary to distribute water throughout each lift. Prevent free water from appearing on surface during, or subsequent to, compaction operations.
- C. Construction Quality Control (CQC) Testing
 - 1. The degree of compaction and moisture content shall be checked by CONTRACTOR'S field geotechnical technician

in accordance with ASTM D-2922 and ASTM D-3017 (or other ENGINEER-approved methods).

- a. Pipe Bedding: One field density test per each 500 lineal feet of trench.
 - b. General fill: One field density test per each 500 lineal feet of trench.
 - c. Aggregate: One field density test for 1,000 square feet of area placed and compacted, minimum one per area installed.
 - d. Moisture-Density Testing: CQC testing shall be based on a minimum of one Standard Proctor Test (ASTM D 698) for each 1000 cubic yards of each soil type used. Additional Standard Proctor Tests may be requested by ENGINEER under the CQC testing to validate compaction results.
- D. Reference densities and moisture content ranges shall be as follows:
1. Pipe Bedding shall be compacted to at least 95% of maximum ASTM D-698 (Standard Proctor) and within -3% to +3% of optimum moisture content.
 2. General fill shall be compacted to at least 92% of maximum ASTM D-698 (Standard Proctor) at -4% to +4% of optimum moisture content.
 3. Aggregate material for access roads and parking areas: at least 95% of maximum ASTM D-698 (Standard Proctor) at -4% to +4% above optimum moisture content. Where field density testing is not possible due to the large particle sizes of aggregate base material, and with ENGINEER'S approval, CONTRACTOR may demonstrate compaction has been achieved using proof-rolling of the surface with heavy earthmoving equipment. Compaction will be considered acceptable when proof-rolling demonstrates less than 1-inch deflection.

3.08 GRADING

- A. General: Uniformly grade areas within limits of grading under this Section, including adjacent transition areas. Smooth-finish surface within specified tolerances, compact with uniform levels or slopes between points where elevations are indicated or between such points and existing grades.

3.09 ROAD CROSSINGS

- A. Install replacement pavement per VDOT specifications or as provided for in other technical specifications for this project.
- B. Place annular seals in carrier pipe with cut out for pipeline. Grout against seal to form moisture gas barrier.
- C. Pipe bedding not required below carrier pipe.

3.10 CONSTRUCTION QUALITY CONTROL AND ASSURANCE TESTING

- A. CONTRACTOR shall provide the services of a materials Construction Quality Control (CQC) Testing geotechnical field technician to perform field compaction and moisture content testing in accordance with ASTM D-2922 and ASTM D-3017, as well as moisture-density relationship per ASTM D698. Locations for field density testing are subject to review and approval of the ENGINEER and OWNER.
- B. Construction Quality Assurance (CQA) testing performed by the OWNER will be in addition to and does not replace Construction Quality Control (CQC) testing provided by the CONTRACTOR.
- C. If the tests indicate that the soil does not comply with the above prescribed limitations, the CONTRACTOR shall, at his own expense, recompact or remove and reinstall the fill as deemed necessary by the ENGINEER. Should heavy precipitation of rain, snow, or sleet occur during the backfilling operations, all operations shall cease and precautionary measures to protect the compacted surface shall be undertaken. Any loss in compaction shall be corrected by the CONTRACTOR at his own expense.
- D. The entire backfilling operation shall be carried out during a period with outdoor temperatures above 32° F, or suitable means to prevent freezing shall be provided. Should freezing weather occur during backfilling operations causing frost, those lifts affected by the frost shall be removed and recompact as directed by the ENGINEER.

END OF SECTION

SECTION 02221 - STRUCTURE DEMOLITION

PART 1 - GENERAL

1.1 RELATED DOCUMENTS

- A. Drawings and general provisions of the Contract, including General and Supplementary Conditions and other Division 1 Specification Sections, apply to this Section.

1.2 SUMMARY

- A. Section Includes:
 - 1. Demolition and removal of buildings and site improvements.
 - 2. Removing below-grade construction.
 - 3. Disconnecting, capping or sealing, and abandoning in-place site utilities.

1.3 DEFINITIONS

- A. Remove: Detach items from existing construction and legally dispose of them off-site unless indicated to be removed and salvaged.

1.4 MATERIALS OWNERSHIP

- A. Unless otherwise indicated, demolition waste becomes property of Contractor.
- B. Historic items, relics, antiques, and similar objects including, but not limited to, cornerstones and their contents, commemorative plaques and tablets, and other items of interest or value to Owner that may be uncovered during demolition remain the property of Owner.
 - 1. Carefully salvage in a manner to prevent damage and promptly return to Owner.

1.5 INFORMATIONAL SUBMITTALS

- A. Schedule of Building Demolition Activities: Indicate the following:

1. Detailed sequence of demolition work, with starting and ending dates for each activity.
2. Temporary interruption of utility services.
3. Shutoff and capping or re-routing of utility services.

1.6 QUALITY ASSURANCE

- A. Regulatory Requirements: Comply with governing EPA notification regulations before beginning demolition. Comply with hauling and disposal regulations of authorities having jurisdiction.
- B. Standards: Comply with ANSI/ASSE A10.6 and NFPA 241.

1.7 PROJECT CONDITIONS

- A. Buildings to be demolished will be vacated and their use discontinued before start of the Work.
- B. Owner assumes no responsibility for buildings and structures to be demolished.
- C. Hazardous Materials: It is not expected that hazardous materials will be encountered in the Work.
 1. Hazardous materials will be removed by Owner before start of the Work.
 2. If materials suspected of containing hazardous materials are encountered, do not disturb; immediately notify Architect and Owner. Hazardous materials will be removed by Owner under a separate contract.
- D. On-site storage or sale of removed items or materials is not permitted.

PART 2 - PRODUCTS (Not Used)

PART 3 - EXECUTION

3.1 EXAMINATION

- A. Verify that utilities have been disconnected and capped before starting demolition operations.
- B. Verify that hazardous materials have been remediated before proceeding with building demolition operations.

3.2 PREPARATION

- A. Existing Utilities: Locate, identify, disconnect, and seal or cap off indicated utilities serving buildings and structures to be demolished.
 - 1. Arrange to shut off indicated utilities with utility companies.
 - 2. Cut off pipe or conduit a minimum of 24 inches below grade. Cap, valve, or plug and seal remaining portion of pipe or conduit after bypassing according to requirements of authorities having jurisdiction.

3.3 PROTECTION

- A. Existing Utilities: Maintain utility services to remain and protect from damage during demolition operations.
 - 1. Do not interrupt existing utilities serving adjacent occupied or operating facilities unless authorized in writing by Owner and authorities having jurisdiction.
 - 2. Provide temporary services during interruptions to existing utilities, as acceptable to Owner and authorities having jurisdiction.
 - a. Provide at least 72 hours' notice to occupants of affected buildings if shutdown of service is required during changeover.
- B. Temporary Protection: Erect temporary protection, such as walks, fences, railings, canopies, and covered passageways, where required by authorities having jurisdiction and as indicated. Comply with requirements in Division 1 Section "Temporary Facilities and Controls."
 - 1. Protect existing site improvements, appurtenances, and landscaping to remain.
 - 2. Erect a plainly visible fence around drip line of individual trees or around perimeter drip line of groups of trees to remain.

3.4 DEMOLITION, GENERAL

- A. General: Demolish indicated buildings and site improvements completely. Use methods required to complete the Work within limitations of governing regulations and as follows:
 - 1. Do not use cutting torches until work area is cleared of flammable materials. Maintain portable fire-suppression devices during flame-cutting operations.

2. Maintain fire watch during and for at least 8 hours after flame cutting operations.
3. Maintain adequate ventilation when using cutting torches.
4. Locate building demolition equipment and remove debris and materials so as not to impose excessive loads on supporting walls, floors, or framing.

B. Explosives: Use of explosives is not permitted.

3.5 DEMOLITION BY MECHANICAL MEANS

A. Proceed with demolition of structural framing members systematically, from higher to lower level.

B. Remove debris from elevated portions of the building by chute, hoist, or other device that will convey debris to grade level in a controlled descent.

C. Below-Grade Construction: Demolish foundation walls and other below-grade construction that are within footprint of new construction and extending 5 feet outside footprint indicated for new construction. Abandon below-grade construction outside this area.

1. Remove below-grade construction, including basements, foundation walls, and footings, to at least 12 inches below grade.

D. Existing Utilities: Demolish existing utilities and below-grade utility structures that are within 5 feet outside footprint indicated for new construction. Abandon utilities outside this area.

1. Fill abandoned utility structures with satisfactory soil materials according to backfill requirements in Division 2 Section "Earthwork Outside Buildings."

3.6 SITE RESTORATION

A. Site Grading: Uniformly rough grade area of demolished construction to a smooth surface, free from irregular surface changes. Provide a smooth transition between adjacent existing grades and new grades.

3.7 DISPOSAL OF DEMOLISHED MATERIALS

A. Remove demolition waste materials from Project site and legally dispose of them in an EPA-approved landfill acceptable to authorities having jurisdiction. See Division 2 Section "Construction Waste Management" for recycling and disposal of demolition waste.

1. Do not allow demolished materials to accumulate on-site.
2. Remove and transport debris in a manner that will prevent spillage on adjacent surfaces and areas.

B. Do not burn demolished materials.

3.8 CLEANING

A. Clean adjacent structures and improvements of dust, dirt, and debris caused by building demolition operations. Return adjacent areas to condition existing before building demolition operations began.

1. Clean roadways of debris caused by debris transport.

END OF SECTION 02221

SECTION 15050 – LFG PIPELINE UNDERGROUND PIPE AND ACCESSORIES

PART 1 - GENERAL

1.01 DESCRIPTION

- A. Scope of Work: The CONTRACTOR shall supply all materials, equipment, and labor needed to install, test, and make ready for use underground all pipe, pipe fittings, and valves as specified herein and as indicated on the Drawings.
 - 1. All piping, pipe fittings and devices that will be in contact with landfill gas shall be suitable for landfill gas application.
- B. Related Work Described Elsewhere
 - 1. Section 02220 – Pipeline trenching and backfilling
 - 2. Section 15190 – Pipeline aboveground pipe and accessories

1.02 SUBMITTALS

- A. The CONTRACTOR shall prepare and submit to the OWNER, for review and approval, certificates of compliance on materials furnished and manufacturer's brochures containing complete information and instructions pertaining to the storage, handling, installation, inspection, maintenance, and repair of each type of pipe, pipe fitting, and valve furnished.

1.03 REFERENCES

- A. The publications listed below form a part of this specification to the extent referenced. The publications are referred to in the text by basic designation only. Use of the most recent version is required.

AMERICAN SOCIETY FOR TESTING AND MATERIALS (ASTM)

ASTM D 1248 Specification for Polyethylene Plastics Molding and Extrusion Materials

ASTM D 3350 Specification for Polyethylene Plastics Pipe and Fittings Materials

AMERICAN NATIONAL STANDARD INSTITUTE (ANSI)

ANSI B 31.8 Code for Pressure Piping, Appendix N

PLASTICS PIPING INSTITUTE (PPI)

PPI TR-31/9-79 Technical Report
PPI TR-4/2002 Technical Report
PPI TR-9/2000 Technical Report

U.S. DEPARTMENT OF TRANSPORTATION

Title 49, Chapter I, Part 192 – Transportation of Natural and Other Gas by Pipeline: Minimum Federal Safety Standards.

INTERNATIONAL ORGANIZATION FOR STANDARDIZATION (ISO)

ISO 12162:1995 Thermoplastics Materials for Pipes and Fittings for Pressure Applications – Classification and Designation – Overall Service (Design) Coefficient

PART 2 - PRODUCTS

2.01 HIGH DENSITY POLYETHYLENE (HDPE) PIPE

A. General:

1. All HDPE pipe and fittings greater than 3-inch diameter as indicated on the Drawings shall be Standard Dimension Rating (SDR) 17 (minimum) high density polyethylene pipes using a 3408 type resin, or approved equal. HDPE pipe and fittings that are 3-inch diameter and less shall be SDR 11.
2. Pipe shall be extruded from a Type III, Class C, Category 5, Grade P34 compound as described in ASTM D 1248. It shall be classified as cell 345434C according to ASTM D 3350. The pipe shall be manufactured to meet the requirements of ASTM D 2513. Manufacturer's literature shall be adhered to when "manufacturer's recommendations" are specified. All pipe and fittings shall be provided by one manufacturer. Acceptable manufacturers include Piping Products, Inc. (713-675-5374) or Performance Pipe (800-527-0662) or approved equal.

- B. Marking of Materials - All pipe and fittings shall be marked per the requirements of 49 CFR 192.63.

2.02 FLANGES FOR HDPE PIPE

- A. Flanges for HDPE pipe shall be convoluted ductile iron back-up rings with a minimum thickness of 1-inch, as manufactured by Improved Piping Products (925-254-0962), Inc., of Orinda, California or approved equal. Back-up rings shall be finished with zinc chromate primer.
- B. The bolts, studs, nuts, and washers for the flanges shall be hot dipped galvanized steel. All studs and bolts shall be coated with Polykin Primer, or approved equivalent. Below grade flanges shall be wrapped in 5-mil polyethylene sheeting, just after installation and prior to backfilling, to help prevent corrosion.

2.03 VALVES

C. General

- 1. All valves shall be complete with all necessary operators, actuators, hand wheels, chain wheels, extension stems, floor stands, worm and gear operators, operating nuts, chains, wrenches, and other accessories or appurtenances which are required for the proper completion of the work. Operators, actuators, and other accessories shall be sized and furnished by the valve supplier and factory mounted.
- 2. Valves and operators shall be suitable for the exposure they are subject to, e.g., buried and landfill gas. Valves shall have all safety features required by OSHA.
- 3. Unless otherwise shown, valves shall be the same size as the adjoining pipe.

D. Butterfly Valves

- 1. Unless otherwise noted, valves shall be butterfly bubble tight, wafer design, with a PVC body, nitrile seat, and compatible with a flat face flange, as manufactured by Asahi/America or equal. If required, stem extensions shall be stainless steel in an epoxy coated steel outer housing with a gear box assembly mounted on top and equipped with a removable manual operating wheel.

E. Labcock Valves

- 1. Labcock valves shall be 3/8-inch PVC with EPDM seats and seals. Valves shall have MPT (Male Pipe Thread) on one end and hose connection on the other end.

2.04 FITTINGS

- A. All 90° turns shall be constructed using 3X radius elbows, unless otherwise noted.
- B. Provide standard stock fittings. Special, nonstandard fittings require approval by ENGINEER.

PART 3 - EXECUTION

3.01 GENERAL

- A. Pipe shall be stored or stacked so as to prevent damage by marring, crushing, or piercing. Maximum stacking height shall be limited to 6 feet.
- B. Pipe and pipe fittings shall be handled carefully in loading and unloading. They shall be lifted by hoists and lowered on skidways in such a manner as to avoid shock. Derricks, ropes, or other suitable equipment shall be used for lowering the pipe into the extraction well borings. Pipe and pipe fittings shall not be dropped or dumped.

3.02 HDPE PIPE HANDLING

- A. HDPE pipe shall not be bent more than the minimum radius recommended by the manufacturer for type, grade, and SDR. Care shall be taken to avoid imposing strains that will overstress or buckle the HDPE piping or impose excessive stress on the joints.

3.03 JOINING HDPE PIPE

- A. Only two methods shall be utilized to joining HDPE pipe: heat fusion and mechanical joining.
 - 1. Mechanical Joining shall be accomplished with HDPE flange adapters, neoprene gaskets, and ductile iron back-up flanges, and shall be used only where shown on the Drawings.
 - 2. Heat Fusion joints shall be made in accordance with manufacturer's step by step procedures and recommendations. Fusion equipment and a trained operator shall be provided by the CONTRACTOR. Pipe fusion equipment shall be of the size and nature to adequately weld

all pipe sizes and fittings necessary to complete the project. Branch saddle fusions shall be made in accordance with manufacturer's recommendations and step-by-step procedures. Branch saddle fusion equipment will be of the size to facilitate saddle fusion within the pipe trench. Heat fusion shall be performed outside of the trench whenever practical. Before heat fusing pipe, each length shall be inspected for the presence of dirt, sand, mud, shavings, and other debris. Any foreign material shall be completely removed. At the end of each day, all open ends of fused pipe shall be capped or otherwise covered to prevent entry by animals or debris.

3. Electro-Fusion will be allowed. Certified technicians must install electro-fusion fittings. CONTRACTOR must notify the OWNER PROJECT MANAGER 24-hours in advance of installing fittings.
4. As per the manufacturer's instructions, no fusion shall be performed in precipitation unless a shelter is provided.

3.04 HDPE PIPE INSTALLATION

- A. Pipe installation shall comply with the requirements of ASTM D 2321, PPI TR-31/9-79, and the manufacturer's recommendations.
- B. Lengths of fused pipe to be handled as one segment shall not exceed 400 feet.
- C. The OWNER shall be notified prior to any pipe being installed in the trench in order for him/her to have an opportunity to inspect the following items:
 1. Butt and saddle fusions.
 2. Pipe integrity.
 3. Trench excavation for rocks and foreign material.
 4. Proper trench slope (where applicable).
 5. Trench contour to ensure the pipe will have uniform and continuous support.
- D. Any irregularities found during inspections must be corrected before lowering the pipe into the trench. Pipe shall be allowed sufficient time to adjust to trench temperature prior to any testing, segment tie-ins, and/or backfilling.
- E. Tie-ins shall be made out of the trench whenever possible. When tie-ins are to be made only in the trench, a hole shall be excavated large enough to ensure an adequate and safe work area.

- F. Below grade piping shall be marked with metallic locator/warning tape to be buried in the trench above the pipe.

3.05 FLANGED CONNECTIONS

- A. Flanged connections for PE pipe shall be installed via mechanical joining.
- B. The CONTRACTOR shall wrap and tape the flanges and bolts in 5 mil polyethylene sheeting prior to backfilling to help protect the assembly from corrosion.

3.06 PIPE SUPPORTS

- A. All piping and valves shall be supported in such a manner as to prevent any stress being transmitted between sections and connected equipment and appurtenances.

3.07 SEGMENT TESTING

- A. The HDPE pipeline shall be subjected to an air test per 49 CFR 192.513 and as described herein to detect any leaks in the piping. Testing shall be performed below grade (inside the trench). The CONTRACTOR shall accept the responsibility for locating, uncovering (if previously backfilled), and repairing any leaks detected during testing.
- B. Like size piping shall be welded together into testing segments not to exceed 1000 ft. Segments shall be connected to a testing apparatus on one end and fitted with welded caps on all openings.
- C. Any section of pipe that fails to meet the stipulated pressure test shall be checked by the CONTRACTOR and corrective measures taken. The test shall then be repeated, at no additional cost to the OWNER, until test results meet the specified requirements.
- D. The tests should be performed when the pipe will be out of direct sunlight.
- E. No pipe installation will be accepted unless and until it meets the pressure test requirements.
- F. Equipment: CONTRACTOR shall provide the following equipment for the pressure test:
 - 1. Pneumatic compressor separator-dryer system capable of providing oil-free, dry air and equipped with one or more full

- capacity, safety-relief valves set at a pressure of not more than 105 percent of the required test pressure.
2. A polyethylene flange adaptor with a PVC blind flange at test pipe end. Polyethylene reducers shall be utilized to adapt test flange to size of pipe being tested. Tapped and threaded into the blind flange shall be a temperature gauge 0 to 100 degrees C, a “Schraeder tire valve” to accommodate an air compressor hose, a ball valve to release pipe pressure at completion of test, and a pressure measuring device.
 3. Pressure Measuring Device: A digital manometer or approved equal capable of measuring positive pressures of air and other non-corrosive gases over a range of 0 to 100 psig.

G. Procedure:

1. Pneumatic testing shall be performed using accurately calibrated instruments and oil-free, dry air. Tests shall be performed on piping after the piping has been completely installed. All parts of the piping system shall be subjected to the test pressure of 50 psig for 1 hour at a temperature not to exceed 100⁰ F.
2. CONTRACTOR shall recognize the hazards associated with air testing and shall take all necessary precautions to protect test personnel. All piping to be tested shall be secured to prevent damage to adjacent piping and equipment in the event of a joint failure. Any appurtenant instruments or devices that could be damaged by the test shall be removed from the piping or suitably isolated prior to applying the test.
3. Test Records: Records shall be made of each piping system installation during the test. These records shall include:
 - a. Date of test.
 - b. Description and identification of piping tested.
 - c. Test pressure.
 - d. Remarks, to include such items as:
 - 1) Leaks (type, location).
 - 2) Repairs made on leaks.
 - e. Certification by CONTRACTOR and signed acknowledgement by OWNER.

- H. The OWNER shall be notified prior to commencement of the testing procedure.

- I. A final 24-hour test shall be conducted over the entire length of the pipeline, once construction is completed. The final pressure test shall be recorded with a chart recorder. Final test results shall be submitted to OWNER.
 1. Pressure for 24-hr test shall be 10 psig.
 2. Pressure drop during the test shall not exceed one percent of the testing gauge pressure over the test period.

3.08 TEST FAILURE

- A. The following steps shall be performed when a pipe segment of pipeline fails the tests described above.
 1. The pipe and all fusions shall be inspected for cracks, pinholes, or perforations.
 2. All blocked risers and capped ends shall be inspected for leaks.
 3. Leaks shall be located and/or verified by applying a soapy water solution and observing soap bubble formation.
- B. All pipe and fused joint leaks shall be repaired by cutting out the leaking area and refusing the pipe.

3.09 PIPELINE CLEANING

- A. The pipeline may be cleaned in sections as needed by the CONTRACTOR. Use a pipeline pig for cleaning activities.
- B. The entire length of pipeline shall be pigged by CONTRACTOR upon completion of installation. The CONTRACTOR must notify the OWNER 24-hours in advance of pigging procedures.

END OF SECTION

SECTION 15190 – LFG PIPELINE ABOVEGROUND PIPE AND ACCESSORIES

PART 1 GENERAL

1.1 SUMMARY

- A. Section Includes:
 - 1. Fuel piping above grade.
 - 2. Pipe supports.
 - 3. Valves, strainers, gauges, and other accessories
- B. Related Sections:
 - 1. Section 15050 – Pipeline underground pipe and accessories

1.2 REFERENCES

- A. American Society of Mechanical Engineers:
 - 1. ASME B31.9 - Building Services Piping.
- A. American Society for Testing and Materials:
 - 1. ASTM A240 - Specification for Heat-Resisting Chromium and Chromium-Nickel Stainless Steel Plate, Sheet, and Strip for Pressure Vessels.
- B. American Welding Society:
 - 1. AWS D1.1 - Structural Welding Code - Steel.
- C. Manufacturers Standardization Society of the Valve and Fittings Industry:
 - 1. MSS SP 58 - Pipe Hangers and Supports - Materials, Design and Manufacturer.
 - 2. MSS SP 69 - Pipe Hangers and Supports - Selection and Application.
 - 3. MSS SP 89 - Pipe Hangers and Supports - Fabrication and Installation Practices.
 - 4. MSS SP 110 - Ball Valves Threaded, Socket-Welding, Solder Joint, Grooved and Flared Ends.
- D. National Fire Protection Association:
 - 1. NFPA 54 - National Fuel Gas Code.

1.3 DEFINITIONS

- A. Where the designation LFG is used, it is the abbreviation for landfill gas.

1.4 SUBMITTALS

- A. Section 01300 - Submittals.
- B. Shop Drawings: Indicate system layout, pipe sizes, location, and elevations.
- C. Product Data:
 - 1. Piping: Submit data on pipe materials, fittings, and accessories.
 - 2. Valves, strainers, regulators, meters, and gauges: Submit manufacturers catalog information.
 - 3. Supports: Submit manufacturers catalog information including load capacity.
 - 4. Provide manufacturer's certification the materials are acceptable for use within LFG.

1.5 CLOSEOUT SUBMITTALS

- A. Project Record Documents: Record actual locations of valves, piping system, and system components.
- B. Operation and Maintenance Data: Operation and Maintenance instructions, spare parts lists, and assembly views.

1.6 QUALITY ASSURANCE

- A. Perform Work in accordance with NFPA 54 standard.
- B. Perform Work in accordance with ASME B31.9 code for installation of piping systems.

1.7 DELIVERY, STORAGE, AND HANDLING

- A. Accept valves on site in shipping containers with labeling in place. Inspect for damage.
- B. Protect piping and fittings from soil and debris with temporary end caps and closures. Maintain in place until installation.

1.8 FIELD MEASUREMENTS

- A. Verify field measurements prior to fabrication.

PART 2 PRODUCTS

2.1 GENERAL

- A. All piping, pipe fittings and accessories (e.g., valves, strainers, flow meters) that will be in contact with landfill gas shall be suitable for landfill gas application. Parts in contact with LFG shall be stainless steel or coated with corrosion-resistant synthetics.

2.2 LFG GAS PIPING, ABOVEGROUND

- A. Stainless Steel Pipe: ASTM A240 Schedule 40, Type 304L.
 - 1. Fittings: Stainless steel, wall thickness equal to or greater than pipe.
 - 2. Joints: NFPA 54, threaded or welded to ASME B31.9.

2.3 PIPE SUPPORTS

- A. Brackets Manufacturer(s):
 - 1. TOLCO a brand of NIBCO
 - 2. Substitutions: Approved equal.
- B. Conform to Federal Specification WW-H-171E, Type 32 and Manufacturers Standardization Society SP-69, Type 31.
- C. Light Welded Bracket: Carbon Steel.

2.4 BALL VALVE

- A. Manufacturer(s):
 - a. 1. Swagelok, 60 Series
 - 2. Substitutions: approved equal
- B. 100 psig minimum; 316 SS body, ball, stem, and flanges; regular port; Teflon seats and stuffing box ring; blow-out proof stem; lever handle with balancing stops; threaded ends.

2.5 STRAINERS

- A. Manufacturers:
 - 1. Armstrong, Model E7SC-2
 - 2. Substitutions: approved equal

- B. 2" pipe fittings, threaded, SS body 100 psig CWP, Y pattern with 316 stainless steel perforated screen (233, 0.045" perforations per square inch).

2.6 FLOW METER

- A. Flow meter:
 - 1. Thermal Instrument Company, Model 600-9,
 - 2. Rosemount, Model 3095MFA Mass ProBar,
 - 3. Substitutions: approved equal.

2.7 GAUGES

- A. Manufacturers:
 - 1. Dwyer Instruments, Model: Magnehelic 2015, Buna-N Diaphragm and Impregnated Case
 - 2. Wika, Model 632.50,
 - 3. Substitutions: approved equal.
- B. Stainless steel case, Range: 0-20" W.C., Size: 4", Wetted Parts: 316 Stainless Steel, Window: laminated safety glass, Accuracy: +or- 1.5% of span, appropriate for use in harsh environment (i.e., exposure to hydrogen sulfide).

PART 3 EXECUTION

3.1 PREPARATION

- A. Ream pipe and tube ends. Remove burrs. Bevel plain end ferrous pipe.
- B. Remove scale and dirt, on inside and outside, before assembly.
- C. Prepare piping connections to equipment with flanges or unions.

3.2 PIPE SUPPORTS

- A. Prime coat exposed steel supports.

3.3 INSTALLATION - ABOVEGROUND PIPING

- A. Install piping in accordance with NFPA 54.

- B. Join underground piping and aboveground piping with appropriate flange adapters to transition from HDPE to Stainless Steel Pipe. The transition shall be below ground surface.
- C. Provide non-conducting dielectric connections wherever jointing dissimilar metals. Install in accordance with NACE RP-01-69.
- D. Route piping in orderly manner and maintain gradient.
- E. Install piping to conserve building space and not interfere with use of space.
- F. Install piping to allow for expansion and contraction without stressing pipe, joints, or connected equipment.
- G. Install valves with stems upright or horizontal, not inverted.
- H. Protect piping systems from entry of foreign materials by temporary covers, completing sections of the work, and isolating parts of completed system.

3.4 SEGMENT TESTING – ABOVEGROUND ONLY

- A. The pipeline shall be subjected to an air test per NFPA 54 (Part 4: Inspection, Testing and Purging) and as described herein to detect any leaks in the piping.
- B. The CONTRACTOR shall accept the responsibility for locating and repairing any leaks detected during testing.
- C. Segments shall be connected to testing apparatus on one end and fitted with caps on all openings. Pressure regulators shall be disconnected prior to pressure test.
- D. The segment to be tested should be allowed time to reach constant and/or ambient temperature before initiating the test.
- E. The test pressure shall be 50 psig. The test medium shall be air.
- F. Pressure drop during the test shall not exceed one percent of the testing gauge pressure over a period of one hour.
- G. Equipment for this testing procedure will be furnished by the CONTRACTOR. This shall consist of a temperature gauge 0 to 100 degrees C, a "Schraeder tire valve" to accommodate an air compressor hose, a ball valve to release pipe pressure at completion of test, and a pressure measuring device. The pressure measuring device shall be a digital manometer capable of

measuring positive pressures of air and other non-corrosive gases over a range of 0 to 50 psig.

- H. CONTRACTOR may coordinate aboveground pipe testing with underground pipe testing to combine tests.

3.5 TEST FAILURE

- A. The following steps shall be performed when a pipe segment fails the one percent - one hour test described above:
- B. The pipe and all fittings shall be inspected for cracks, pinholes, or perforations.
- C. Leaks shall be located and/or verified by applying a soapy water solution and observing soap bubble formation.
- D. All pipe leaks shall be repaired.
- E. After all leaks are repaired, a retest shall be performed in accordance with Section 3.5.

END OF SECTION

BID

Stoney Run Community Center Phase II

BID PRICE

Provide all labor, material and equipment for the construction of a new 52,851 s.f., one-story building, Stoney Run Community Center, 15198 Warwick Boulevard, Newport News, Virginia. The work includes in addition to architectural items, civil and sitework, landscaping, plumbing, heating ventilating air conditioning (HVAC), fire protection, and electrical systems as described in the documents prepared by James River Architects, 11832 Rock Landing Drive, Suite 304, Newport News, Virginia.

BASE BID TOTAL (\$ _____)

Award will be made based on the Base Bid Total to the lowest responsive and responsible bidder.

ALTERNATES:

Alternate No. 1: State the amount to be added to or deducted from the Base Bid for the LED site lighting, as described in the Division 1 Specification Section "Alternates."

\$ _____ (Figures Only)

Alternate No. 2: State the amount to be deducted from the Base Bid for deleting the water feature, as described in the Division 1 Specification Section "Alternates."

\$ _____ (Figures Only)

Alternate No. 3: State the amount to be deducted from the Base Bid for using the temporary parking layout, as described in the Division 1 Specification Section "Alternates."

\$ _____ (Figures Only)

Alternate No. 4: State the amount to be deducted from the Base Bid. To omit all demolition work located within the area denoted as Phase 2B as described in the Division 1 Specifications Section Alternates.

\$ _____ (Figures Only)

Alternate No. 5: State the amount to be deducted from the Base Bid to omit all demolition work located within the area denoted as Phase 2C as described in the Division 1 Specification section Alternates.

\$ _____ (Figures Only)

UNIT PRICES:

Stated unit prices shall be used to adjust the contract amount for both additions and deductions to the work. The item costs shall include the material, labor, and equipment costs. Failure to quote the unit prices may result in the rejection of the bid. The Owner reserves the right to delete unit prices from the executed contract that are deemed unreasonable.

ITEM	ADD OR DEDUCT
1. Bulk Earth Excavation and Disposal Off-Site	_____/cy
2. Compacted Engineered Fill	_____/cy
3. VDOT No. 57 Fill	_____/cy
4. Temporary asphalt pavement patch	_____/cy

CONTRACT
BID
Stoney Run Community Center Phase II

BID PRICE

Provide all labor, material and equipment for the construction of a new 52,851 s.f., one-story building, Stoney Run Community Center, 15198 Warwick Boulevard, Newport News, Virginia. The work includes in addition to architectural items, civil and sitework, landscaping, plumbing, heating ventilating air conditioning (HVAC), fire protection, and electrical systems as described in the documents prepared by James River Architects, 11832 Rock Landing Drive, Suite 304, Newport News, Virginia.

BASE BID TOTAL (\$ _____)

Award will be made based on the Base Bid Total to the lowest responsive and responsible bidder.

ALTERNATES:

Alternate No. 1: State the amount to be added to or deducted from the Base Bid for the LED site lighting, as described in the Division 1 Specification Section "Alternates."

\$ _____ (Figures Only)

Alternate No. 2: State the amount to be deducted from the Base Bid for deleting the water feature, as described in the Division 1 Specification Section "Alternates."

\$ _____ (Figures Only)

Alternate No. 3: State the amount to be deducted from the Base Bid for using the temporary parking layout, as described in the Division 1 Specification Section "Alternates."

\$ _____ (Figures Only)

Alternate No. 4: State the amount to be deducted from the Base Bid. To omit all demolition work located within the area denoted as Phase 2B as described in the Division 1 Specifications Section Alternates.

\$ _____ (Figures Only)

Alternate No. 5: State the amount to be deducted from the Base Bid to omit all demolition work located within the area denoted as Phase 2C as described in the Division 1 Specification section Alternates.

\$ _____ (Figures Only)

UNIT PRICES:

Stated unit prices shall be used to adjust the contract amount for both additions and deductions to the work. The item costs shall include the material, labor, and equipment costs. Failure to quote the unit prices may result in the rejection of the bid. The Owner reserves the right to delete unit prices from the executed contract that are deemed unreasonable.

ITEM	ADD OR DEDUCT
1. Bulk Earth Excavation and Disposal Off-Site	_____/cy
2. Compacted Engineered Fill	_____/cy
3. VDOT No. 57 Fill	_____/cy
4. Temporary asphalt pavement patch	_____/cy

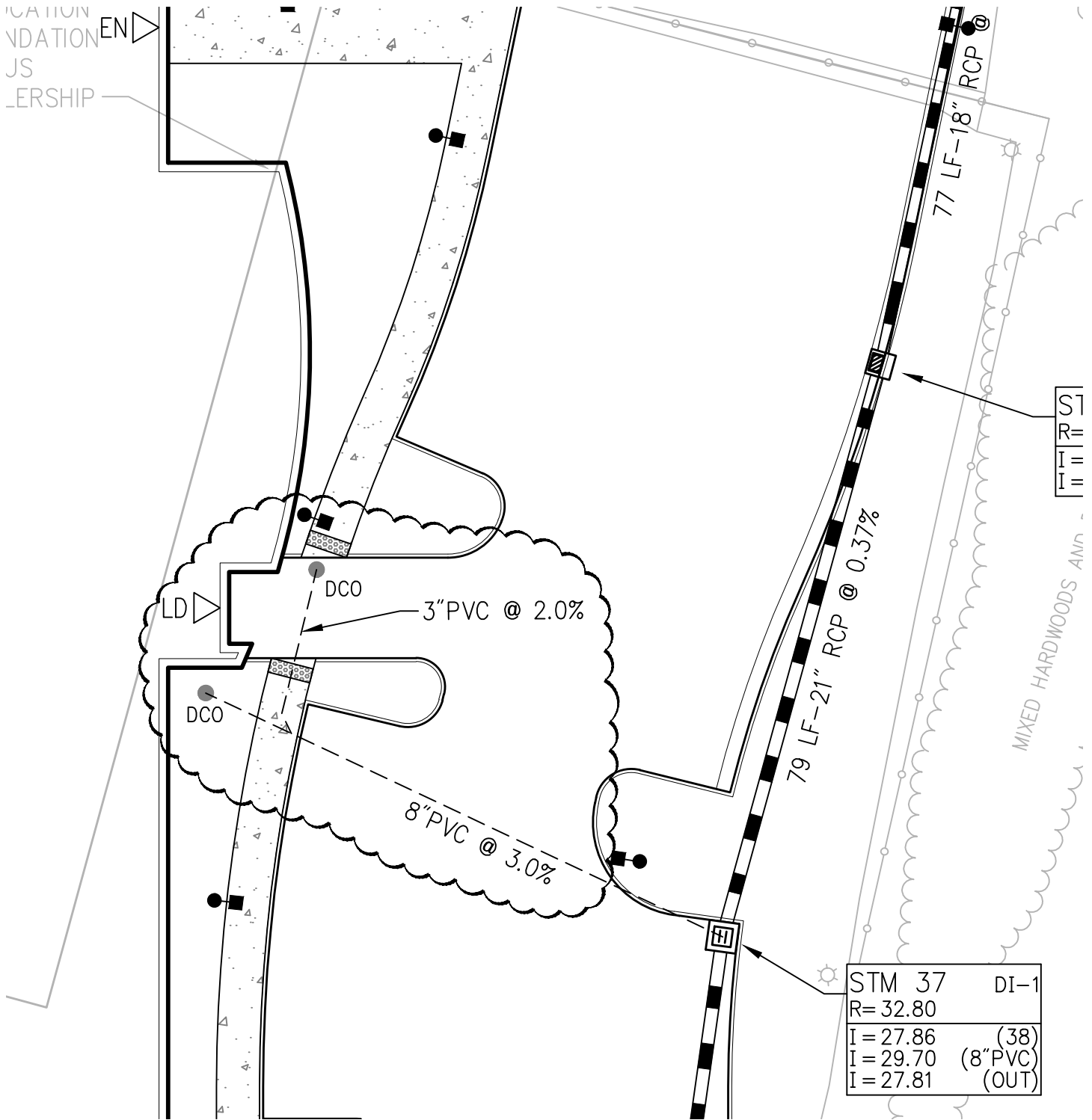

Stoney Run Community Center - Phase II

James River Architects

ARCHITECTURE • PLANNING • LANDSCAPE ARCHITECTURE
A PROFESSIONAL CORPORATION

11832 ROCK LANDING DRIVE SUITE 304 NEWPORT NEWS VIRGINIA 23606-4278
PHONE 757-595-5504 FAX 757-595-5582

COMM. NO. 05003

DRAWN BY: VHB

SK-C1

DATE: 1/27/2011

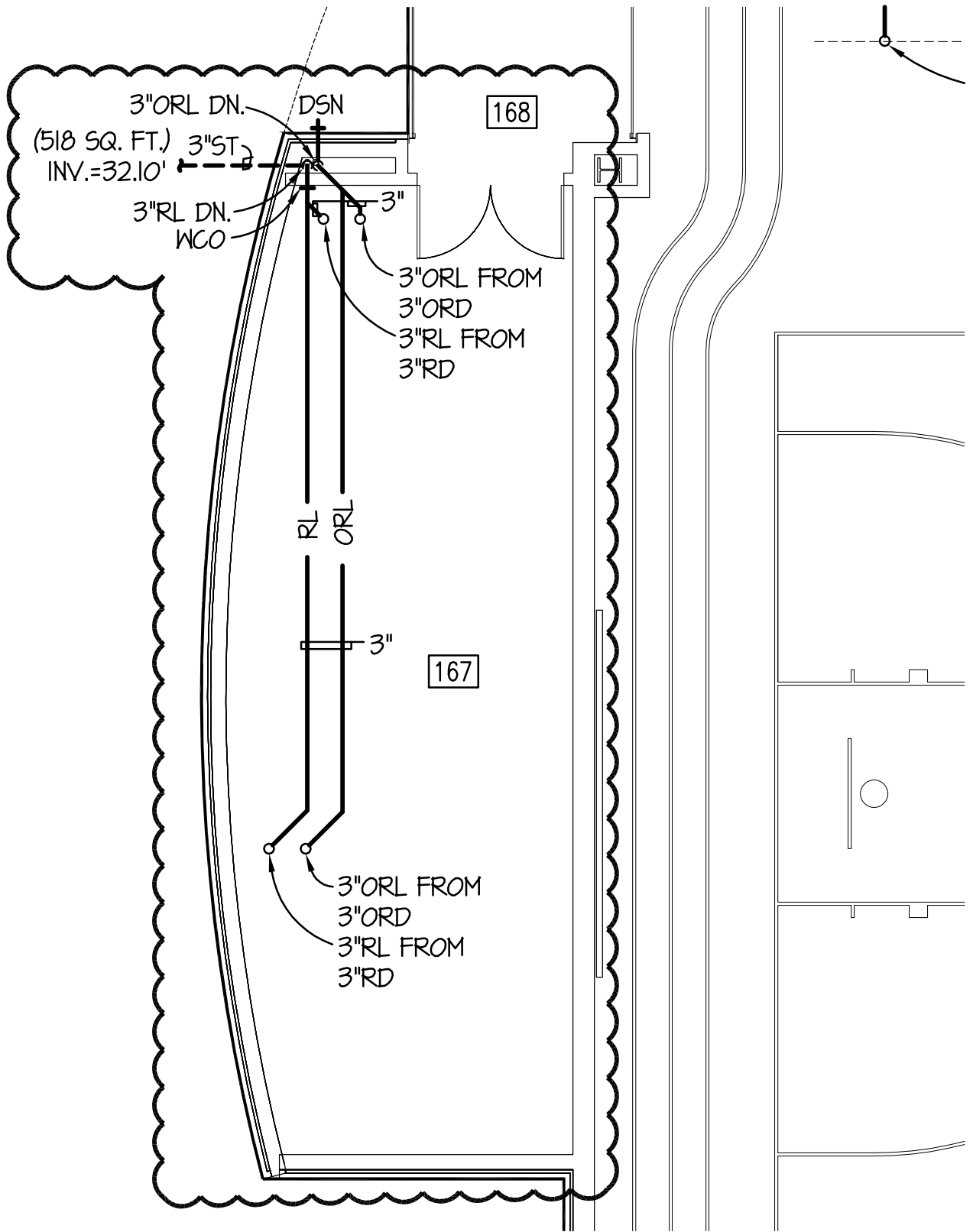

Stoney Run Community Center - Phase II

James River Architects

ARCHITECTURE • PLANNING • LANDSCAPE ARCHITECTURE
A PROFESSIONAL CORPORATION

11832 ROCK LANDING DRIVE SUITE 304 NEWPORT NEWS VIRGINIA 23606-4278
PHONE 757-595-5504 FAX 757-595-5582

COMM. NO. 05003

DRAWN BY: PRF

SK-P1

DATE: 01-26-11

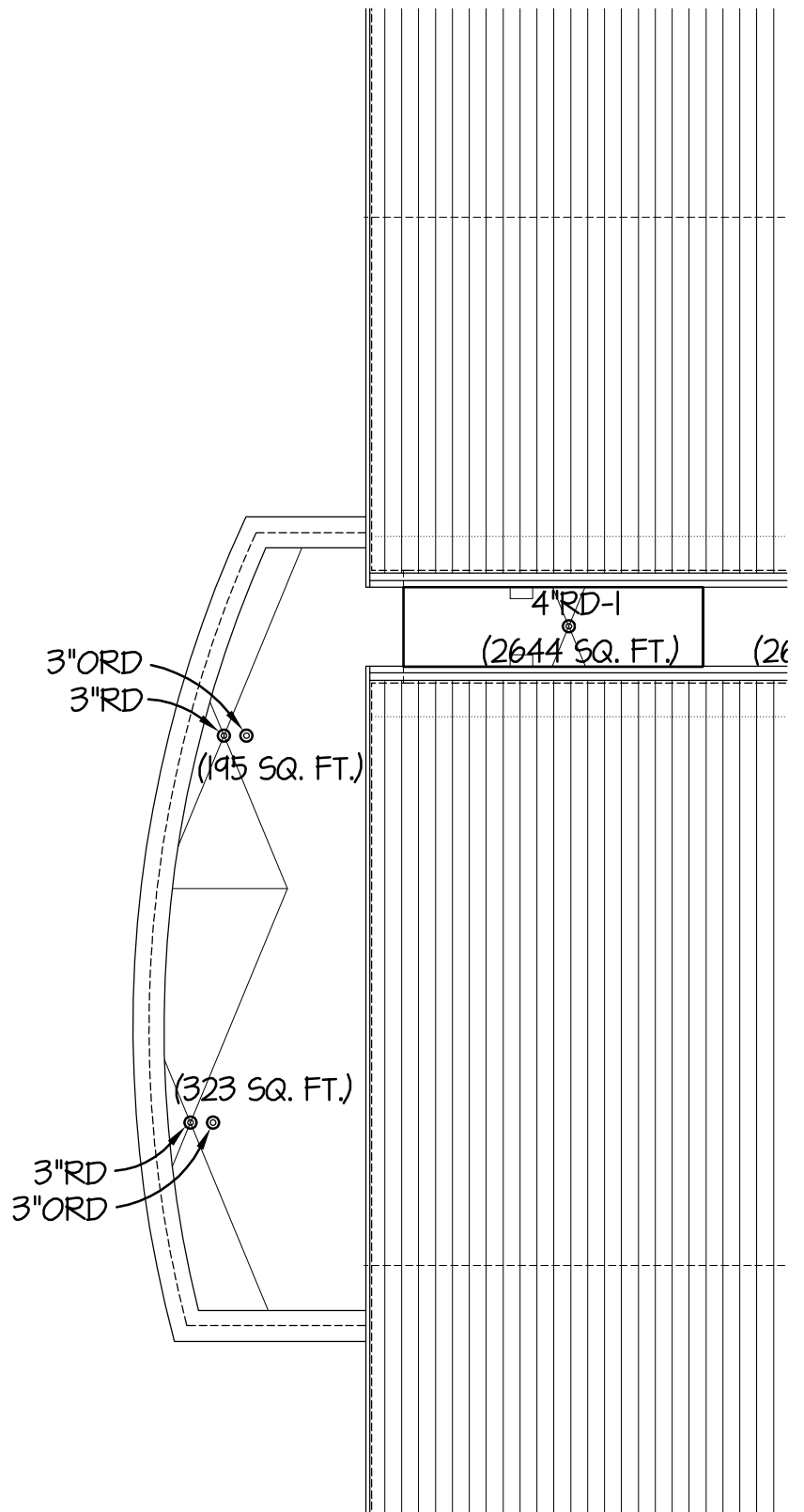

Stoney Run Community Center - Phase II

James River Architects

ARCHITECTURE • PLANNING • LANDSCAPE ARCHITECTURE
A PROFESSIONAL CORPORATION

11832 ROCK LANDING DRIVE SUITE 304 NEWPORT NEWS VIRGINIA 23606-4278
PHONE 757-595-5504 FAX 757-595-5582

COMM. NO. 05003

DRAWN BY: PRF

SK-P2

DATE: 01-26-11

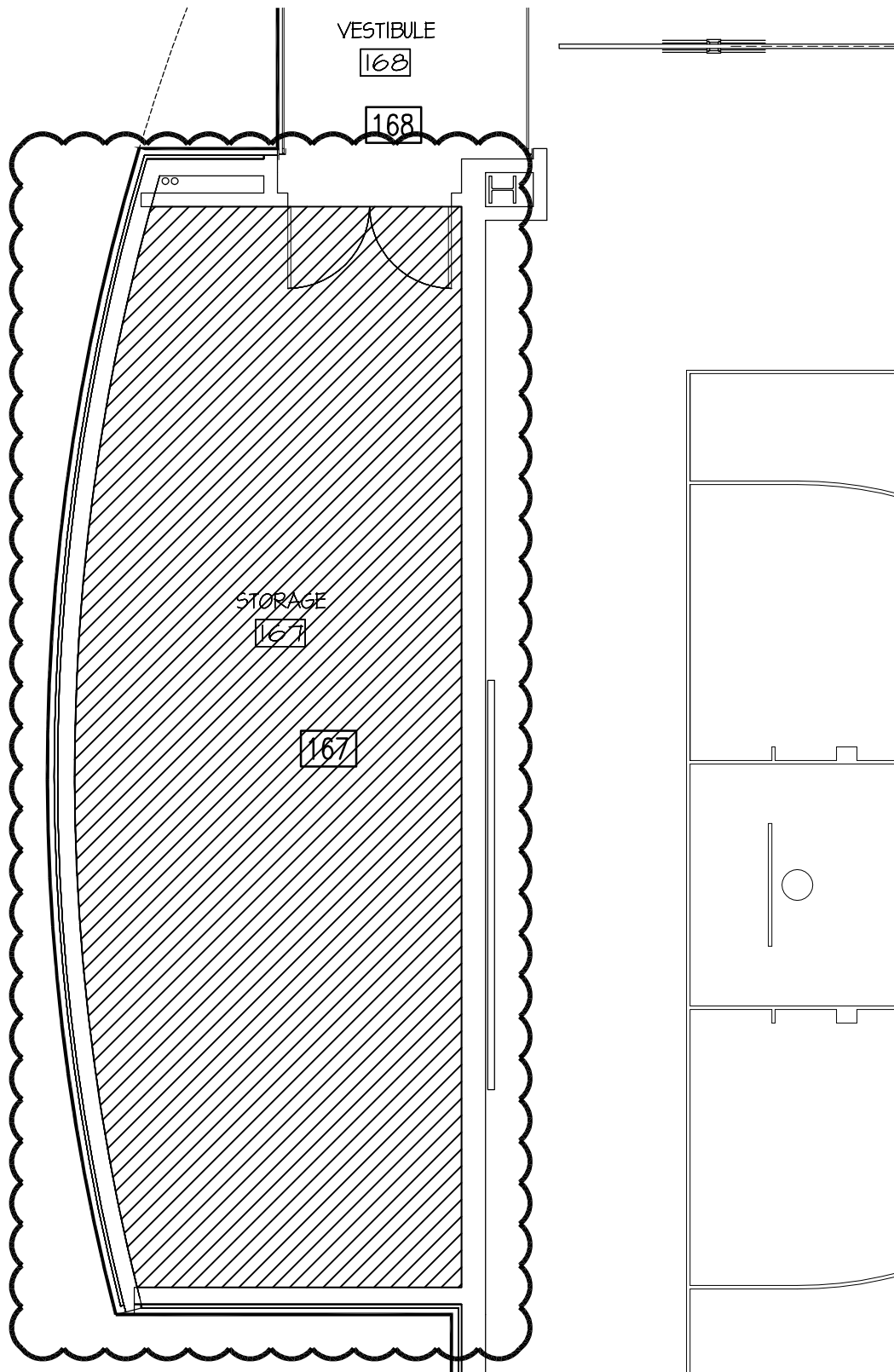

Stoney Run Community Center - Phase II

James River Architects

ARCHITECTURE • PLANNING • LANDSCAPE ARCHITECTURE

A PROFESSIONAL CORPORATION

11832 ROCK LANDING DRIVE SUITE 304 NEWPORT NEWS VIRGINIA 23606-4278

PHONE 757-595-5504 FAX 757-595-5582

COMM. NO. 05003

DRAWN BY: PRF

SK-SP1

DATE: 01-26-11