



Invitation for Bids

IFB#2011-2967B-1705

November 15, 2010

City of Newport News Office of the Purchasing Director

2400 Washington Avenue

Newport News, VA 23607

Phone: (757) 926-8032 Fax: (757) 926-8493

www.nngov.com/purchasing

Demolition of 3114 Terminal Avenue

Bids, subject to the conditions and instructions contained herein, will be received at the above office of the Purchasing Agent, 4th Floor, City Hall, 2400 Washington Avenue, Newport News, Virginia, until the due date and hour shown below (local prevailing time), for furnishing the following described equipment, materials, and/or services, for delivery and/or performance F.O.B. NEWPORT NEWS, VIRGINIA.

Scope of Work: Contractor is responsible for removal and legal disposal of all personal property from within the structure, Old Nicosia's Restaurant, 3114 Terminal Avenue, demolition of the structure and removal of restaurant parking lot, removal and legal disposal of all debris, and clearing, grading and seeding of the areas disturbed per these specifications.

Bid Due: November 30, 2010 @ 2:30 P.M.

Contract Officer: *Kimberly A. Kapalka*
Kimberly A. Kapalka, C.P.M., Senior Buyer, kkapalka@nngov.com and Brenda Vines, Assistant Buyer, bvines@nngov.com

THE ORIGINAL SECTION A AND ONE DUPLICATE COPY IS REQUESTED

In compliance with this Invitations for Bids, and subject to all the conditions thereof, the undersigned offers, if this bid is accepted within (60) calendar days from the date of the opening, to furnish any or all of the items and/or services upon which prices are quoted, at the price set opposite each item, to be delivered at the time and place specified herein. The undersigned certifies he has read, understands, and agrees to all terms, conditions, and requirements of this bid, and is authorized to contract on behalf of firm named below.

This Public Entity does not discriminate against faith-based organizations.

Company Name: _____

Address: _____

City/State/Zip: _____

Telephone: _____ Fax No.: _____

Email: _____

Print Name: _____ Title: _____

Signature: _____ Date: _____

This form must be signed. Initial all pages on the space provided, as well as subsequent addenda.

TABLE OF CONTENTS

Invitation For BidsCover Page

Table of ContentsTC-1

Section A

Conditions and InstructionsC&I-1 thru C&I-13

Notice to Contractors.....NTC-1

Bid, SWAM Objectives, Anti-collision Certification, and Exceptions.....Q-1 thru Q-6

Section B

Insurance Endorsement.....INS-1 thru INS-4

Performance BondPB-1 thru PB-3

Labor and Material Payment Bond.....LMB-1 thru LMB-4

Section C

Special Construction Conditions.....SCC-1 thru SCC-4

Environmental Information & RequirementsE-1 thru E-2

General ConditionsGC-1 thru GC-3

Special Traffic ConditionsSTC-1

Backfilling, Grading & SeedingBGS -1 thru BGS -5

DrawingsDrawings 1 & 2

Section A

CONDITIONS AND INSTRUCTIONS

Rev: 10/08/2010

1. All bids shall be submitted on and in accordance with this form. If more space is required to furnish a description of the goods and/or services and/or services bid, or delivery terms, the bidder may attach a letter hereto that will be made a part of the bid. In case of conflict, the bid may be deemed non-responsive. The City's published specifications shall supersede any additional writings submitted with the bid. Such writings should be clearly marked and noted on the exception page.
2. All bids shall be submitted sealed, plainly marked showing the bid number, date and time. The entire solicitation document is to be returned when submitting a bid, unless otherwise directed by the bid document. Failure to return all pages may result in a determination that the submittal is non-responsive.
3. Bids and amendments thereto, if received by the Purchasing Department after the date and time specified for bid opening, will not be considered. It will be the responsibility of the bidder to see that their bid is received by the Purchasing Department as specified. There will be no exceptions. Date of postmark will not be considered. Telephone, facsimile, electronic and verbal bids will not be accepted. Prices or changes shown on the outside of an envelope will not be considered in determination of low bid.
4. If City Hall is closed for business at the time scheduled for bid opening, for whatever reasons, sealed bids will be accepted and opened on the next business day of the City, at the originally scheduled hour.
5. Each bid is received with the understanding that the acceptance in writing by the City of the bidder to furnish any or all of the goods and/or services described therein, shall constitute a contract between the bidder and the City, which shall bind the bidder on his part to furnish and deliver the goods and/or services quoted at the prices stated and in accordance with the conditions of the accepted bid; and the City on its part to order from such bidder, except for causes beyond reasonable control; and pay for, at the agreed prices, all goods and/or services specified and delivered.
6. Bidders have the right to request withdrawal of their bids from consideration due to error by giving notice not later than two business days after bids are publicly opened. Work papers showing evidence of error(s) may be required. Upon request, administrative withdrawal procedures will be provided that shall be used for that purpose.
7. If issued, addenda to this solicitation will be posted on the Purchasing Department's website (www.nngov.com/purchasing). It is the bidder's responsibility to check the website or contact the Purchasing Department prior to the submittal deadline to ensure that the bidder has a complete, up-to-date package.
8. The solicitation document maintained by the Purchasing Department, in the bid file folder, shall be considered the official copy. In the case of any inconsistency between bid documents submitted to the City, but not clearly listed on the exception page of the document as an exception by the bidder, the language of the official copy shall prevail.

Furthermore, any exception or changes to the specifications made by the bidder may be cause to disqualify your bid.

9. Award will be made to the lowest responsive and responsible bidder. The quality of the goods and/or services to be supplied, their conformity with the specifications, their suitability to the requirements, the delivery terms, qualifications and references will be taken into consideration in making an award. Length of time for delivery as well as price may be considered in awarding the bid.

Unless canceled or rejected, a responsive bid from the lowest responsible bidder shall be accepted as submitted; except that if the bid from the lowest responsible bidder exceeds available funds, the purchasing director may negotiate with the apparent low bidder to obtain a contract price within available funds.

Upon making an award, or giving notice of intent to award, the City will place appropriate notice on the public bulletin board located outside of the Purchasing Department at City Hall. Notice of award may also appear on the Purchasing Website: www.nngov.com/purchasing or www.demandstar.com.

10. The City reserves the right to reject any and all bids, and to waive any informality if it is determined to be in the best interest of the City.
11. Prices shall be stated in units of quantity specified. No additional charges shall be passed on to the City, including any applicable taxes, delivery, or surcharges. Prices quoted shall be the final cost to the City.
12. All prices and notations should be in ink or typewritten. Mistakes may be crossed out and corrections made in ink and must be initialed and dated in ink by the person signing the bid.
13. In case of error in the extension of prices, the unit price shall govern.
14. The time of proposed delivery must be stated in definite terms. If time of delivery for different goods and/or services varies, the bidder shall so state.
15. Samples, when requested, must be furnished free of expense, and upon request, if not destroyed, will be returned at the bidder's risk and expense.
16. Unless qualified by the provision "NO SUBSTITUTE", the use of the name of the manufacturer, brand make or catalog designation in specifying an item does not restrict bidders to the manufacturer, brand, make or catalog designation identification. This is used simply to indicate the character, quality and/or performance equivalence of the goods and/or services desired. The goods and/or services on which bids are submitted must be of such character, quality and/or performance equivalence that it will serve as that specified. In submitting bids on goods and/or services other than as specified, bidder shall furnish complete data and identification with respect to the alternate goods and/or services they propose to furnish.

Consideration will be given to bids submitted on alternate goods and/or services to the extent that such action is deemed to serve the best interests of the City. If the bidder does not indicate that the goods and/or services he proposes to furnish is other than specified, it will be construed to mean that the bidder proposes to furnish the exact goods and/or services described.

17. The apparent silence of these specifications and any supplemental specifications as to any detail or the omission from the specifications of a detailed description concerning any point shall be regarded as meaning that only the best commercial practices are to prevail and correct type, size and design are to be used. All interpretations of these specifications shall be made on the basis of this statement.
18. All bids must be signed by a responsible officer or employee having the authority to sign for the firm. The bidder agrees that its contract performance shall be in strict conformance with the contract documents.
19. By signing this bid, the bidder assigns to the City any and all rights that it may have under the antitrust laws of the United States and the Commonwealth of Virginia in any way arising from or pertaining to this bid. This provision is remedial in nature and is to be liberally construed by any court in favor of the City.
20. The bidder certifies by signing this Invitation for Bid that this bid is made without prior understanding, agreement, or accord with any other person or firm submitting a bid for the same goods and/or services and that this bid is in all respects bona fide, fair, and not the result of any act of fraud or collusion with another person or firm engaged in the same line of business or commerce. Any false statement hereunder may constitute a felony and can result in a fine and imprisonment, as well as civil damages.
21. **Hold Harmless and Indemnification:** The contractor shall defend, indemnify and hold the City, and City's employees, agents, and volunteers, harmless, from and against any and all damage claim, liability, cost, or expense (including, without limitation, attorney's fees and court costs) of every kind and nature (including, without limitation, those arising from any injury or damage to any person, property or business) incurred by or claimed against the contractor, its employees, agents, and volunteers, or incurred by or claimed against the City, City's employees, agents, and volunteers, arising out of, or in connection with, the performance of all services hereunder by the contractor. This indemnification and hold harmless includes, but is not limited to, any financial or other loss including, but not limited to, any adverse regulatory, agency or administrative sanctions or civil penalties, incurred by the City due to the negligent, fraudulent or criminal acts of the contractor or any of the contractor's officers, shareholders, employees, agents, contractors, subcontractors, or any other person or entity acting on behalf of the contractor. Unless otherwise provided by law, the contractor indemnification obligations hereunder shall not be limited in any way by the amount or type of damages, compensation, or benefits payable by or for the contractor under worker's compensation acts, disability benefit acts, other employee benefit acts, or benefits payable under any insurance policy. This paragraph shall survive the termination of the contract including any renewal or extension thereof.

22. The contractor agrees to defend and save the City, its agents, officials, volunteers and employees, harmless from liability of any nature or kind, for use of any copyright, composition, secret process, patented or unpatented invention, goods and/or services or appliances furnished or used in the performance of the contract, or which the contractor is not the patentee, assignee, or licensee, to the same extent as provided in the above paragraph.
23. The contractor shall keep fully informed of all federal, state and local laws, ordinances and regulations that in any manner affect the conduct of the work. The contractor shall at all times observe and comply with all such laws, ordinances and regulations.
24. **The contractor certifies that he does not and shall not during the performance of the contract for goods and services in the Commonwealth, knowingly employ unauthorized aliens as defined in the federal Immigration Reform and Control Act of 1986, as amended.**
25. All bidders or offerors organized or authorized to transact business in the Commonwealth pursuant to Title 13.1 or Title 50, as amended, shall include the identification number issued to it by the State Corporation Commission. Any bidder or offeror that is not required to be authorized to transact business in the Commonwealth as a foreign business entity under Title 13.1 or Title 50, as amended, or as otherwise required by law shall include in its bid or proposal a statement describing why the bidder or offeror is not required to be so authorized.

Number or Statement: _____

Any business entity that enters into a contract with a public body pursuant to this chapter shall not allow its existence to lapse or its certificate of authority or registration to transact business in the Commonwealth, if so required under Title 13.1 or Title 50, as amended, to be revoked or cancelled at any time during the term of the contract. The City may void any contract with a business entity if the business entity fails to remain in compliance with the provisions of this section.

26. **Contractor's License:** If any of the services promulgated under this solicitation consist of construction work, it is required under Title 54.1, Chapter 11, Code of Virginia for a contractor who performs or manages construction, removal, repair, or improvements when the total value referred to in a single contract or project is:

Seventy thousand dollars (\$70,000) or more, or the total value of all such construction, removal, repair or improvements undertaken by such person within any twelve-month period is five hundred thousand dollars (\$500,000) or more shall show evidence of being licensed as a **Class A Contractor**.

Seventy-five hundred dollars (\$7,500.00) or more, but less than seventy thousand dollars (\$70,000) or the total value of all such construction, removal, repair or improvements undertaken by such person within any twelve-month period is one hundred and fifty thousand dollars (\$150,000) or more, but less than five hundred thousand dollars (\$500,000) shall show evidence of being licensed as a **Class B Contractor**.

Over one thousand dollars (\$1,000) but no more than seventy-five hundred dollars (\$7,500) or the total value of all such construction, removal, repair, or improvements undertaken by such person within any twelve-month period is no more than one hundred and fifty thousand dollars shall show evidence of being licensed as a **Class C Contractor**.

The City shall require master certification as a condition of licensure or certification of electrical, plumbing and heating, ventilation and air conditioning contractors.

A valid business license from the City may be required. The bidder shall complete whichever of the following notations as appropriate:

"Licensed Class A Virginia Contractor No. _____."

"Licensed Class B Virginia Contractor No. _____."

"Licensed Class C Virginia Contractor No. _____."

27. Availability of Funds: A contract shall be deemed in force only to the extent of appropriations available to each department for the purchase of such goods and/or services or services. The City's extended obligations on those contracts that envision extended funding through successive fiscal periods shall be contingent upon actual appropriations for the following years.
28. **Payment Terms:**
- a) Payment terms shall be "2%-20, Net 30 days" unless otherwise stated by the bidder on this submittal form. Alternate terms may be offered by bidder for prompt payment of bills.
 - b) Payment terms shall be considered in determining the low bidder.
 - c) Discount period shall be computed from the date of proper receipt of the contractor's correct invoice, or from the date of acceptable receipt of the goods and/or services, whichever is latest.
 - d) The payment terms stated herein must appear on the contractor's invoice. Failure to comply with this requirement shall result in the invoice being returned to the contractor for correction.
 - e) Late payment charges shall not exceed the allowable rate specified by the Commonwealth of Virginia Prompt Payment Act. (1% per month)
29. In event of default by the contractor, the City reserves the right to procure the goods and/or services and/or services from other sources, and hold the contractor liable for any excess cost occasioned thereby.

30. Appeals Procedure: Upon your request, administrative appeals information will be provided that shall be used for hearing protests of a decision to award or an award, appeals from refusal to allow withdrawal of bids, appeals from disqualification, appeals for debarment or suspension, or determinations of non-responsibility and appeals from decision or disputes arising during the performance of a contract. To be timely, all appeals shall be made within the time period set forth in Chapter 2, divisions 4 and 5 of the City Code.
31. **It is the policy of the City of Newport News to facilitate the establishment, preservation, and strengthening of small businesses and businesses owned by women and minorities and to encourage their participation in the City's procurement activities. Toward that end, the City of Newport News encourages these firms to compete and encourages non-minority firms to provide for the participation of small businesses and businesses owned by women and minorities through partnerships, joint ventures, subcontracts, and other contractual opportunities. Bidder is requested to complete the SMB, MBE and WBE Business Objectives form within this document.**
32. The City has a directory of Newport News Small, Women-owned and Minority (SWAM) businesses. The directory is available at www.nngov.com/purchasing.
33. This public body does not discriminate against faith based organizations.
34. Non-Discrimination: During the performance of this contract, the contractor agrees as follows:
- (a) It will not discriminate against any employees or applicants for employment because of race, religion, color, sex, national origin, age, disability, or any other basis prohibited by federal or state law relating to discrimination in employment, except where one or more of these are a bona fide occupational qualification reasonably necessary to the normal operations of the contractor. The contractor agrees to post in conspicuous places available to employees and applicants for employment, notices setting forth the provisions of this non-discrimination clause.
 - (b) The contractor will be and state that he is an equal opportunity employer in all solicitations or advertisements for employees.
 - (c) Notices, advertisements and solicitations placed in accordance with federal law, rule or regulation shall be deemed sufficient for the purpose of meeting the requirements of this section.
- The contractor will include the provisions of the foregoing paragraphs (a), (b) and (c) in every subcontract or purchase order of over ten thousand dollars so that the provisions will be binding upon each subcontractor or vendor.
35. During the performance of this contract, the contractor agrees to (i) provide a drug-free workplace for the contractor's employees; (ii) post in conspicuous places, available to employees and applicants for employment, a statement notifying employees that the

unlawful manufacture, sale, distribution, dispensation, possession, or use of a controlled substance or marijuana is prohibited in the contractor's workplace and specifying the actions that will be taken against employees for violations of prohibition; (iii) state in all solicitations or advertisements for employees placed by or on behalf of the contractor that the contractor maintains a drug-free workplace; and (iv) include the provisions of the foregoing clauses in every subcontract or purchase order of over \$10,000, so that the provisions will be binding upon each subcontractor or vendor.

For the purposes of this subsection, "A drug-free workplace" means a site for the performance of work done in connection with a specific contract awarded to a contractor in accordance with this subsection, the employees of whom are prohibited from engaging in the unlawful manufacture, sale, distribution, dispensation, possession or use of any controlled substance or marijuana during the performance of the contract.

36. Assignment of Contract: A contract shall not be assignable by the contractor in whole or in part without the written consent of the City.
37. **Governing Law and Venue:** This solicitation and any resulting contract is subject to the laws of the Commonwealth of Virginia and the Newport News City Code. Any litigation with respect thereto shall be brought in the courts of the City of Newport News, Virginia, or the United States District Court for the Eastern District of Virginia, Newport News Division.
38. Severability: If any provision of this contract or the application thereof to any person or circumstances shall to any extent be invalid or unenforceable, the remainder of this contract, or the application of such provision to persons or circumstances other than those which it is invalid or unenforceable, shall not be affected hereby, and each provision of this contract shall be valid and enforced to the full extent permitted by law.
39. Scheduling and Delays – The parties to any contract resultant of this solicitation acknowledge that all or part of the work to be performed hereunder may be delayed and extended at the option of the City. Such delays may be caused by delays, denials, and modifications of the various state or federal permits, or for other reasons. The City shall not be required to pay any of the Contractor's direct or indirect costs, or claims for compensation, extended overhead, or other damage or consequential damages arising out of or related to any delays or interruptions required or ordered by the City. If the City delays the project for any reason for a continuous period of 6 months or more, the City and Contractor will negotiate a mutually agreeable adjustment to the Contractor's award amount.
40. **Termination by the City or the Contractor, or both, for convenience (Not applicable to contracts subject to the Department of Engineering Standard dated August 1, 1983, as amended, or the Department of Public Utilities "General Conditions"):**

The parties may terminate the contract at any time by mutual written agreement.

In addition, if the contract is an extended term contract, after completion of the first contract period, either party may terminate the contract without penalty or financial

obligation, except that the parties remain liable for performance of all terms, conditions, and obligations through the date of termination. Written notice of termination shall be given to the other party a minimum of sixty (60) days prior to its effective date.

41. **Termination for Cause (Not applicable to contracts subject to the Department of Engineering Standard dated August 1, 1983, as amended, or the Department of Public Utilities “General Conditions”):**

In the event that the contractor shall for any reason or through any cause be in default of the terms, conditions, or obligations of the contract documents, the City may give the contractor written notice of such default and terminate the contract. All terms, conditions, and obligations of the contract documents are considered material.

The City may, in its discretion, provide the contractor an opportunity to cure the default, if curable, prior to termination. Unless a different duration is provided in the notice of default, or agreed upon by the parties in writing, the contractor shall have fourteen (14) calendar days to cure the default from the date such notice is mailed to the contractor unless notification is by facsimile or personal delivery, in which case the opportunity to cure shall commence upon delivery of the notice. Upon failure of the contractor to cure the default, the City may immediately terminate the contract effective as of the mailing or delivery of the default notice. If the City terminates the contract, the contractor shall remain liable for performance of all terms, conditions, and obligations through the date of termination. Termination by the City shall not constitute a waiver by the City of any other rights or remedies available to the City by law or contract.

42. **Bid Bond:** A bidder’s bond or certified check in the amount of five percent (5%) of the amount bid shall accompany any bid in excess of \$100,000.00 for the bid to be acceptable.

43. **Performance and Labor and Material Payment Bond:** The Contractor shall have ten (10) days from the date of the City’s request to provide a performance bond and a labor and material payment bond, (Use only the forms provided by the City, unless otherwise approved by the City Attorney) in the amount of the contract price, as security for faithful performance of the work in strict conformity with the Contract Documents and for payment of all persons who perform labor and furnish materials in prosecution of the work. The surety on such bonds shall be duly authorized to do business in the Commonwealth of Virginia and be satisfactory to the City.

44. **Direct contact with City departments other than Purchasing, on the subject of this bid is expressly forbidden except with the foreknowledge and permission of the contracting officer. Violation may result in a determination that your firm is ineligible for award.**

45. Questions or comments related to this solicitation should be directed to the contract officer, whose name and contact information appears on the front of this document. All questions must be submitted in writing (facsimile or email); telephonic inquiries will not be considered.

46. Successful bidder shall furnish all required bonds, certificates of insurance and required endorsements on City approved forms included in this bid package. Any other forms are not acceptable and shall not be approved by the City Attorney's office. Time is critical on this work and non-compliance will delay the work and may be cause to make award to the next qualified bidder.
47. **Engineering Standard Specifications:** This contract consists of plans, technical specifications and the Department of Engineering Standard Specifications. The Standard Specification are available for \$15.75, including tax, per copy non-refundable, from the Department of Engineering, City Hall Building, 8th floor, Newport News, Virginia 23607, telephone (757) 926-8611. In the Standard Specification any/all references to the Director of Engineering, which involves the initial Invitation for Bid and prior to an actual contract being awarded shall be defined and interpreted as the City's Purchasing Director or their designee.
48. **Liquidated Damages:** TIME IS OF THE ESSENCE ON THIS CONTRACT. Failure of the Contractor to complete the work within the time allowed will result in damages being sustained by the City. Such damages are, and will continue to be, impracticable and extremely difficult to determine. For each consecutive calendar day in excess of the time specified for completion of the work, the Contractor shall pay to the City, or have withheld from monies due it, the sum of **\$300.00 per day**.

Execution of the contract under these specifications shall constitute agreement by the City and Contractor that this amount per day is the minimum value of the costs and actual damage caused by failure of the Contractor to complete the work within the allotted time, that such sum is liquidated damages and shall not be construed as a penalty, and that such sum may be deducted from payments due the Contractor if such delay occurs.

Permitting the Contractor to continue and finish the work or any part thereof after the contract time or adjusted contract time, as pertinent, has expired shall in no way operate as a waiver on the part of the City or any of its rights under the contract.

Payment of liquidated damages shall not release the Contractor from obligations in respect to the fulfillment of the entire contract, nor shall the payment of such liquidated damages constitute a waiver of the City's right to collect any additional damages which may be sustained by failure of the Contractor to carry out the terms of the contract, it being the intent of the parties that said liquidated damages be full and complete payment only for failure of the Contractor to complete the work on time.

49. **Permits,** Contractor shall be responsible for furnishing all necessary permits as required by the City Newport News prior to start of construction. The Contractor is required to obtain and pay for all necessary permits along with required bonds and insurance. A minimum \$5,000.00 bond for Right-of-Way permits and a minimum \$2,000.00 for land disturbing permits (based on area disturbed). These bonds are in addition to any bid bond, performance or payment bond required as part of the bid. Contractor shall also be responsible to obtain and pay for any required permits from State or Federal agencies. The project signs, right-of-way permit, land disturbing permit, etc. and associated bonds

shall also be included in this bid price. Proof of approved final inspections relating to these permits shall be required before final payment is made.

50. **Insurance:** The contractor shall maintain adequate liability insurance, which shall protect and save harmless the City of Newport News, Virginia, and its officials from all suits and actions of every kind and description arising from injury or damage to persons and property in the prosecution of said work or in failure to properly safeguard same, and from all claims arising under the workmen's compensation laws. The contractor shall furnish proof of said insurance prior to commencement of services. Separate forms, which name the City as additional insured and as alternate employer, must be included with the Certificate of Insurance. **Please make sure prior to submitting a bid that all insurance endorsements forms have been reviewed by your insurance carrier.**

The Commonwealth of Virginia requires construction contractors and subcontractors to obtain and maintain worker's compensation insurance while performing work on behalf for the City. Evidence of coverage needs to be provided prior to commencement of work.

Sample forms CG 20-10 (naming the City as additional insured for liability claims) and WC 00-03-01 (naming the City as an alternate employer for Worker's Compensation claims); and the Commonwealth's form for Worker's Compensation Certificate of Coverage are attached (**See Section B**).

Contractor shall have ten (10) days from the date of the city's request, to provide insurance documentation. Failure to provide the Certificate and forms within this period may be cause for the City to award a contract to the next responsive bidder, and hold the original contractor liable for excess costs.

51. The Conditions and Instructions in this solicitation are intended to apply to the resulting contract and shall supersede any conflicting terms offered. Any additional conditions a bidder intends to be considered must be submitted with the bid as an exception. Such exceptions may result in a finding that the submittal is 'non-responsive' to the bid, negating possibility of an award to that bidder. Contractual documents submitted by the successful firm after an award will not be accepted.
52. Failure of the contractor to perform the contract by reason of this non-acceptance of additional conditions shall result in termination of the contract by the City, and may result in debarment of the contractor for a period of up to three years. Termination and/or debarment of the contractor shall not constitute a waiver by the City of any other rights or remedies available to the City by law or contract.
53. **Records and Inspection:** The contractor shall maintain full and accurate records with respect to all matters covered under this contract, including, without limitation, accounting records, written policies and procedures, time records, telephone records, and any other supporting evidence used to memorialize, reflect, and substantiate charges or fees related to this contract. The contractor's records shall be open to inspection and subject to audit and/or reproduction, during normal working hours, by the City and its employees, agents or authorized representatives after giving at least three (3) days notice

to contractor by the City. The City shall have access to such records from the effective date of this contract, for the duration of the contract, and for five (5) years after the date of final payment by the City to the contractor pursuant to this contract or any renewal or extension of this contract. The City's employees, agents or authorized representatives shall have access to the contractor's facilities, shall have access to all necessary records, and shall be provided adequate and appropriate work space, in order to conduct audits.

54. **Rights and Remedies Not Waived:** In no event shall the making by the City of any payment to the contractor, or the waiver by the City of any provision under this contract including any obligation of the contractor, constitute or be construed as a waiver by the City of any other provision, obligation, breach of covenant, or any default which may exist under this contract on the part of the contractor, and the making of any such payment by the City while any such breach or default exists shall not impair or prejudice any rights or remedies available to the City.
55. **Entire Agreement:** This contract and any additional or supplementary documents incorporated herein by reference contain all the terms and conditions agreed upon by the parties hereto, and no other agreements, oral or otherwise, regarding the subject matter of this contract or any part thereof shall have any validity or bind any of the parties hereto. This contract shall not be modified, altered, changed or amended unless in writing and signed by the parties hereto.
56. **Independent Contractor:** The contractor and any employees, agents, or other persons or entities acting on behalf of the contractor shall act in an independent capacity and not as officers, employees, or agents of the City.
57. **Conflict:** In the event of a conflict between the contract documents, including these Conditions and Instructions, and the terms of a purchase order or related document issued by the Department of Purchasing, the contract documents shall control.

In the event of a conflict between the Department of Engineering Standard Specifications dated August 1, 1983, as amended, and the contract documents (including the General and Special Conditions), the contract documents shall control unless otherwise provided. In addition, Special Conditions take precedence over General Conditions.

In the event of a conflict between the Department of Public Utilities "General Conditions" and the contract documents (including the General and Special Conditions), the contract documents shall control unless otherwise provided. In addition, Special Conditions take precedence over General Conditions.

58. **Scheduling and Delays:** The parties to any contract resultant of this solicitation acknowledge that all or part of the work to be performed hereunder may be delayed and extended at the option of the City. Such delays may be caused by delays, denials and modifications of the various state or federal permits, or for other reasons. The City shall not be required to pay any of the Contractor's direct or indirect costs, or claims for compensation, extended overhead, or other damage or consequential damages arising out of or related to any delays or interruptions required or ordered by the City. If the City delays the project for any reason for a continuous period of six (6) months or more, the

City and Contractor will negotiate a mutually agreeable adjustment to the Contractor's award amount. **Notwithstanding the above, in construction contracts, to the extent that an unreasonable delay is caused by the acts or omissions of the City due to causes within the City's control, the above waiver or release shall not apply.**

NOTICE TO CONTRACTORS

Bids will be received by the Department of Purchasing of the City of Newport News, Virginia, on the 4th Floor, City Hall Building, 2400 Washington Avenue, no later than **November 30, 2010, at 2:30 P.M. for the Demolition of 3114 Terminal Avenue for NNRHA – Pkg. 5-2010.**

Please be advised that all technical or procedural questions in reference to this project must be directed to Kimberly A. Kapalka, C.P.M., Senior Buyer, kkapalka@nngov.com and copy Brenda L. Vines, Assistant Buyer, bvines@nngov.com of the Department of Purchasing via email and/or fax (757) 926-8038 by November 19, 2010.

Scope of Work – Contractor is responsible for the removal and legal disposal of all personal property from within the structure, Old Nicosia's Restaurant, 3114 Terminal Avenue, demolition of the structure and removal of restaurant parking lot, removal and legal disposal of all debris, and clearing, grading and seeding of the area disturbed per these specifications.

Each bid greater than \$100,000 shall be accompanied by a bidder's bond or a certified check of five percent (5%) of the amount of the bid. Performance and Labor & Material Payment Bond amounting to one hundred percent (100%) of the contract price may be required of the successful contractor.

This contract consists of plans, technical specifications and Department of Engineering Standard Specifications. Plans and technical specifications for said contract are available for free download from our website, www.nngov.com/purchasing. **The Standard Specification are available for \$15.75, including tax, per copy non-refundable, from the Department of Engineering, City Hall Building, 8th floor, Newport News, Virginia 23607, telephone (757) 926-8611. If the Contractor submitting a bid does not have a set of the current Department of Engineering Standard Specifications, a set SHALL BE PURCHASED prior to submitting a bid at a cost of \$15.75, including tax per copy, non-refundable and shall be maintained on the job site at all times until completion of the project.**

The attention of the provider is invited to the provision of Chapter 11 of Title 54.1 of the Code of Virginia regulating the practice of general contracting under which it will be necessary for the provider to show evidence of certificate of registration as provided by said code.

The City of Newport News reserves the right to reject any or all bids.

Everett P. Skipper, P.E., B.C.E.E.
Director of Engineering
2400 Washington Avenue
Newport News, VA 23607

To The City Manager
City of Newport News
Newport News, Virginia

Dear Sir:

In submitting this bid, the undersigned declares that he is, or they are, the only person, or persons, interested in said bid, that it is made without any connection with any person making another bid for the same contract; that the bid is in all respects fair and without collusion, fraud or mental reservation; and that no official of the City, or any person in the employ of the City, is directly or indirectly, interested in said bid, or in the supplies or work in which it relates, or on any portion of the profits thereof.

The undersigned also declares that he had, or they have, examined all the specifications, specifically including the Standard Specifications, August 1, 1983, form of contract, and that he has, or they have, personally inspected the actual location of the work together with the local sources of supply and understands that in signing this bid, he, or they, waive all right to plead a misunderstanding regarding the same.

The undersigned further understands and agrees that he is, or they are, to furnish and provide for the respective item price bid, all necessary materials, machinery, implements, tools, labor, service, et cetera, and to do, and perform all the work necessary under the aforesaid conditions to complete the improvements aforementioned in accordance with the specifications for said improvements which specifications, it is agreed, are a part of this bid, and to accept in full compensation therefore, the Lump Sum price.

Bid

Furnish all labor, materials, equipment, and supervision necessary for the complete removal, proper handling, and legal disposal of all personal property from within the dwelling, demolition of the structures, removal and legal disposal of all debris, and clearing, grading and seeding of the areas disturbed.

3114 Terminal Avenue \$ _____ (Lump Sum Price)

At times demolition projects lend themselves to uncertainties and discoveries not within the scope of work. The City reserves the right to require the successful contractor to provide a performance bond and labor and material bond before award of this project. The pricing of the bond will not be considered to determine the lowest responsive bid.

Contractor may be required to provide performance bond and labor and material bond for Demolition of 3114 Terminal Avenue, IFB 2011-2967B-1705.

Price to furnish performance bond and labor and material bond: \$ _____

NOTE:

1. The Contractor shall be responsible for visiting the project site to ascertain that his bid reflects the amount of work required for a complete functional project constructed in accordance with the intent of the project plans and specifications.
2. The Contractor shall be responsible for the adequacy of equipment submitted for use on the project.
3. Award of the contract shall be in accordance with Section 2-563 of the City Procurement Code and shall be based on the lump sum price as shown on this page.
4. "Time is of the essence"; Therefore, the structures listed in this contract shall be completely demolished, and cleared per specifications within nineteen (19) business days per structure, excluding Sundays and Holidays after notice to proceed or liquidated damages of \$300.00 per day, including any part of a day, shall apply. "Notice to Proceed" shall not be given until all insurances and bonds have been reviewed and accepted by the City Attorney.
5. All work shall comply with the current City of Newport News Standards & Specifications.

On acceptance of this bid for said work, the undersigned does, or do hereby bind himself, or themselves, to enter into a written contract within ten (10) days of award, with the said City, and to give the required bond and surety to perform said work for the consideration above named.

The service provider agrees to complete the entire work within **nineteen (19) days** excluding Sundays and Holidays, from the "Notice to Proceed".

State Contractor License Number _____

Business Name: _____

Address: _____

(Street; PO Box not acceptable)

(City, State and Zip Code)

By: _____ Date: _____

By: _____ Date: _____

ADDENDA
No.

ACKNOWLEDGED
Initial

THE ORIGINAL SECTION A AND ONE DUPLICATE COPY IS REQUESTED. IF CONTRACTOR DESIRES TO MAKE ANY ALTERNATIVE BID ON DIFFERENT TYPE OF CONSTRUCTION THAN ONE CALLED FOR, IT SHALL BE ENCLOSED ON A SEPARATE SHEET.

**SMALL, MINORITY, WOMEN-OWNED
BUSINESS OBJECTIVES**

It is an important business objective of the City to promote the economic enhancement of small businesses (SBE), minority businesses (MBE), and women-owned businesses (WBE). The success of the City to track the amount of business received by SBE, MBE and WBE FIRMS (whether as a prime contractor or a subcontractor) is dependent upon the business community partnering with us in this important endeavor.

If you anticipate **sub-contracting** to any of these businesses in the performance of this contract, you are requested to individually report the total dollars for each business classification. Failure to report the dollars in the categories below may result in the application of stronger requirements being placed on bidders to assure that SBE, MBE and WBE firms receive benefits from City contracts.

Complete the following information and return the form with your package.

1. If you are a SBE, MBE or WBE, please check one of the following boxes:

SBE **MBE** **WBE**

2. In the spaces below, report the anticipated dollars that you intend to subcontract to each business type if a contract is awarded to your firm. (If you do not intend to sub-contract any work to others, even if you are a S/M/WBE, put zeros in the spaces below).

Total **SBE** Dollars to be Sub-contracted \$ _____

Total **MBE** Dollars to be Sub-contracted \$ _____

Total **WBE** Dollars to be Sub-contracted \$ _____

3. If you are not a SBE, MBE, or WBE and you do not plan to utilize such firms in this contract, please state your reasons:

ANTI-COLLUSION CERTIFICATION

The offeror certifies that this bid is made without prior understanding, agreement, or connection with any corporation, firm, or person submitting a bid for the same product and that this bid is in all respects bona fide, fair and not the result of any act of fraud or collusion with another person or firm engaged in the same line of business or commerce. The bidder understands collusive bidding is a violation of Federal law and that any false statement hereunder constitutes a felony and can result in fines, imprisonment, as well as civil damages. The bidder also understands that failure to sign this statement will make the bid non-responsive and unqualified for award.

Signed: _____ Date: _____

Name of Company: _____

Engineering Department Standard Specifications

The bidder certifies that this bid is submitted in compliance with the Special Construction and Conditions and the contractor has obtained a copy of the City of Newport News, Engineering Department Standard Specifications prior to submitting a quote and shall kept a copy on the job site at all times.

Signed: _____ Date: _____

Name of Company: _____

EXCEPTIONS:

Note: Bidder must sign the appropriate statement below, as applicable:

- () Bidder understands and agrees to all terms, conditions, requirements, and specifications stated herein.

Firm:

Signature:

- () Bidder takes exception to terms, conditions, requirements, or specifications stated herein (Bidder must itemize all exceptions below, and return with this IFB submittal):

Firm:

Signature:

Vendors should note that any exceptions taken from the stated terms and/or specifications may be cause for their submittal to be deemed "non-responsive", risking the rejection of their submittal.

Payment terms if other than 2% 20, Net 30 days _____

Payment terms shall be considered in determining the low bidder.

BID RESULTS

Bid results may be obtained from our web site: www.nngov.com/purchasing or www.demandstar.com

Section B

INSURANCE ENDORSEMENTS

Insurance: The contractor shall maintain adequate liability insurance, which shall protect and save harmless the City of Newport News, Virginia, and its officials from all suits and actions of every kind and description arising from injury or damage to persons and property in the prosecution of said work or in failure to properly safeguard same, and from all claims arising under the workmen's compensation laws. The contractor shall furnish proof of said insurance prior to commencement of services. Separate forms which name the City as additional insured and as alternate employer must be included with the Certificate of Insurance. Original signatures (not photocopies) are required and binder numbers will not be accepted.

The Commonwealth of Virginia requires construction contractors and subcontractors to obtain and maintain worker's compensation insurance while performing work on behalf for the City. Evidence of coverage needs to be provided prior to commencement of work.

Sample forms CG 20-10 (naming the City as additional insured for liability claims) and WC 00-03-01 (naming the City as an alternate employer for Worker's Compensation claims); and the Commonwealth's form for Worker's Compensation Certificate of Coverage are attached.

Contractor shall have ten (10) days from notice of intent to award to provide insurance documentation. Failure to provide the Certificate and forms within this period may be cause for the City to award a contract to the next responsive bidder, and hold the original contractor liable for excess costs.

<u>TYPE INSURANCE COVERAGE</u>	<u>LIMITS</u>
1. Workman's Compensation Employer's Liability	Statutory \$100,000.00
2. Comprehensive General Liability with XCU & Contractual included	\$1,000,000.00 each \$1,000,000.00 each Occurrence
3. Property Damage Liability	\$100,000.00 each Occurrence

POLICY NUMBER: _____

COMMERCIAL GENERAL LIABILITY
CG 20 10 10 93

THIS ENDORSEMENT CHANGES THE POLICY. PLEASE READ IT CAREFULLY.

**ADDITIONAL INSURED – OWNERS, LESSEES OR
CONTRACTORS (FORM B)**

This endorsement modifies insurance provided under the following:

COMMERCIAL GENERAL LIABILITY COVERAGE PART

SCHEDULE

Name of Person or Organization:

**City of Newport News
c/o Purchasing Department
2400 Washington Avenue
Newport News, VA 23607**

(If no entry appears above, information required to complete this endorsement will be shown in the Declarations as applicable to this endorsement).

WHO IS AN INSURED (Section II) is amended to include as an insured the person or organization shown in the Schedule, but only with respect to liability arising out of your ongoing operations performed for this insured.

CG 20 10 10 93
Endorsement

Alternate Employer

WC 00 03 01

Policy Amendment

If the following information is not complete, refer to the appropriate information page attached to the policy.

INSURED	POLICY NO.	SEQ. NO.
PRODUCER	EFFECTIVE DATE	

Alternate Employer	Address	SCHEDULE	State of Special or Temporary Employment
City of Newport News, Purchasing Dept. c/o Purchasing Department 2400 Washington Avenue, Newport News, VA			

This endorsement applies only with respect to bodily injury to your employees while in the course of special or temporary employment by the alternate employer in the state named in the Schedule. Part One (Workers Compensation Insurance) and Part Two (Employers Liability Insurance) will apply as though the alternate employer is insured.

Under Part One (Workers Compensation Insurance), we will reimburse the alternate employer for the benefits required by the workers compensation law if we are not permitted to pay the benefits directly to the person entitled to them.

The insurance afforded by this endorsement is not intended to satisfy the alternate employers duty to secure its obligations under the workers compensation law. We will not file evidence of this insurance on behalf of the alternate employer with any government agency.

We will not ask any other insurer of the alternate employer to share with us a loss covered by this endorsement.

Premiums will be charged for your employees while in the course of special or temporary employment by the alternate employer.

Part Four (Your Duties If Injury Occurs) applies to you and the alternate employer. The alternate employer will recognize our right to defend under Parts One and Two and our right to inspect under Part Six.

WORKER'S COMPENSATION

CERTIFICATE OF COVERAGE

Section 11-46.3, Code of Virginia, requires construction contractors and subcontractors to obtain and maintain workers' compensation insurance while performing work on behalf of the Commonwealth of Virginia departments, institutions or agencies. This same requirement applies for work being performed on behalf of local governments.

Evidence of coverage needs to be provided prior to commencement of work.

This form is to be returned to the organization contracting the work.

The undersigned organization stipulates that it either:

A. Has worker's compensation insurance _____ Yes

Insurance Company: _____

Policy Expiration Date: _____

B. Is self-insured for workers' compensation _____ Yes

Title of Construction Contract: **Demolition of 3114 Terminal Avenue, IFB 2011-2967B-1705**

Contract Number: _____

Signed By: _____

Title: _____

Firm Name: _____

Address: _____

Bond # _____

PERFORMANCE BOND

KNOW ALL MEN BY THESE PRESENTS: That we, the undersigned _____
_____, as Principal,
and _____, as
Surety, acknowledge ourselves held and firmly bound unto the City of Newport News, Virginia
as Obligee, in the amount of _____
_____ dollars, (_____) for the payment of which,
well and truly to be made, we hereby jointly and severally bind ourselves, our heirs, executors,
administrators, successors and assigns.

WHEREAS, the said _____
did, on the _____ day of _____, 20____, enter into a contract with the
City of Newport News, Virginia for the **Demolition of 3114 Terminal Avenue, IFB 2011-
2967B-1705**

which said contract is by reference made a part hereof, is hereinafter referred to as the Contract.

NOW, THEREFORE, the condition of this obligation is such that if the Principal shall in all
respects promptly and faithfully comply with and fulfill all the terms and conditions of said
contract, then this obligation shall be void; otherwise it shall remain in full force and effect.

The Surety hereby waives notice of any change, alteration or addition to the terms of the
Contract or extension of time made by the Owner.

Whenever principal shall be, and declared by Obligee to be in default under the Contract, the Surety
may promptly remedy the default, or shall promptly

1. Complete the Contract in accordance with its terms and conditions, or
2. Obtain a bid or bids for completing the Contract in accordance with its terms and conditions, and upon determination by Surety of the lowest responsible bidder, or, if the Obligee elects, upon determination by the Obligee and Surety jointly of the lowest responsible bidder, arrange for a contract between such bidder and Obligee, and make available as work progresses (even though there should be a default or a succession of defaults under the contract or contracts of completion arranged under this paragraph) sufficient funds to pay the cost of completion less the balance of the contract price; but not exceeding, including other costs and damages for which the Surety may be liable hereunder, the amount set forth in the first paragraph hereof. The term "balance of the contract price", as used in this paragraph, shall mean the total amount payable by the Obligee to principal under the Contract and any amendments thereto, less the amount properly paid by Obligee to principal.

It is hereby expressly further understood and agreed that this Bond is also given and made against defective material and workmanship in the said work covered by the said Contract, provided, however, that no suit, action or proceeding, by reason of any defect whatever, shall be brought upon this Bond after one (1) year following (i) completion of the contract, including the expiration of all warranties and guarantees, or (ii) discovery of the defect or breach of warranty, if the action be for such.

No right of action shall accrue on this bond to or for the use of any person or corporation other than the Obligee named herein or the heirs, executors, administrators or successors of Obligee.

SIGNED AND SEALED this _____ day of _____, 20_____.

BY _____

CONTRACTOR

Signature of Authorized
Owner, Partner or Officer

SURETY

BY _____
Attorney In Fact

Attach Original Power of Attorney

City Attorney Use Only
APPROVED AS TO FORM

Bond # _____

LABOR AND MATERIAL PAYMENT BOND

KNOW ALL MEN BY THESE PRESENTS: That we, the undersigned, _____
_____, as Principal, and
_____, as
Surety, acknowledge ourselves held and firmly bound unto the City of Newport News,
Virginia as Obligee in the amount of _____
Dollars (_____) for the payment of which, well and truly to be made, we hereby jointly and
severally bind ourselves, our heirs, executors, administrators, successors and assigns.

WHEREAS, the said _____ did, on the ____ day
of _____, 20____, enter into a contract with the City of Newport News,

Virginia, for the **Demolition of 3114 Terminal Avenue, IFB 2011-2967B-1705** which said
contract is

by reference made a part hereof, as fully and is hereinafter referred to as the Contract. NOW,

THEREFORE, THE CONDITION OF THIS OBLIGATION is such that, if Principal shall
promptly make payment to all claimants as hereinafter defined, for all labor and material used or
reasonably required for use in the performance of the Contract, then this obligation shall be void;
otherwise it shall remain in full force and effect, subject, however to the following conditions:

1. A claimant is defined as one having a direct contract with the Principal or with a
subcontractor of the Principal for labor, material, or both, used or reasonably required for
use in the performance of the Contract, labor and material being construed to also include
that part of water, gas, power, light, heat, oil, gasoline, telephone service or rental of
equipment directly applicable to the Contract.

2. The above-named Principal and Surety hereby jointly and severally agree with the City that every claimant as herein defined, who has not been paid in full before the expiration of a period ninety (90) days after the date on which the last of such claimant's work or labor was done or performed, or materials were furnished by such claimant, may sue on this bond for such sum or sums as may be justly due claimant, and have execution thereon. The City shall not be liable for the payment of any costs or expenses of any such suit.

3. No suit or action shall be commenced hereunder by any claimant:

A. Unless claimant, other than one having a direct contract with the Principal, shall have given written notice of the following:

The Principal, the City, and the Surety above named, within ninety (90) days after such claimant did or performed the last of the work or labor, or furnished the last of the materials for which said claim is made, stating with substantial accuracy the amount claimed and the name of the party to whom the materials were furnished or for whom the work or labor was done or performed.

Such notice shall be served by mailing the same by registered or certified mail, postage prepaid, in an envelope addressed to the Principal, City and Surety, at any place where an office is regularly maintained for the transaction of business, or served in any manner in which legal process may be served in the state in which the aforesaid project is located, save that such service need not be made by a public officer.

B. After the expiration of one (1) year following the date on which Principal ceased work on said Contract, it being understood, however, that if any limitation embodied in this bond is prohibited by any law controlling the construction hereof such limitation shall be deemed to be amended so as to be equal to the

minimum period of limitation permitted by such law.

- C. Other than in a state court of competent jurisdiction in and for the county or other political subdivision of the state in which the Project, or any part thereof, is situated, or in the United States District Court for the district in which the Project, or any part thereof, is situated, and not elsewhere.
- 4. The amount of this bond shall be reduced by and to the extent of any payment or payments made in good faith hereunder, inclusive of the payment by Surety of mechanics' liens which may be filed of record against said improvement, whether or not claim for the amount of such lien be presented under and against this bond.

SIGNED AND SEALED this _____ day of _____, 20_____.

Contractor

BY _____

ATTEST:

Surety

BY _____

ATTORNEY-IN-FACT

Resident Virginia Agent of Surety
(if original agent is non-resident)

Approved
As to Form

City Attorney

Submit with Power of Attorney

SECTION C

SPECIAL CONSTRUCTION CONDITIONS

1. **When the Contractor chooses to work Sunday or any City Holiday, the Contractor shall be required to pay the City for project inspection services for those days. The payment rate is established at \$75.00 per inspector, per hour, for each hour the inspector(s) provides the inspection service, which shall include travel time to and from the site. The Contractor shall submit with each monthly invoice for specific billing period a check payable to the City of Newport News in an amount equivalent to the hours of inspection service times the above rate. There shall be a minimum service time requirement of two (2) hours per inspector.**

2. **The Contractor shall request approval from the City of any scheduled work on Sundays or Holidays a minimum of 72 hours prior to the scheduled work date. Approval by the Director of the Department of Engineering or his representative is required. There is no obligation or requirement that the City provide this service, and the City cannot guarantee the availability of an inspector. Note: This requirement may not apply to contracts where work hour restrictions established by the City will require Sunday or Holiday work.**

3. The contractor shall take all precautions necessary to protect adjacent property. Damage caused to adjacent properties by the contractor shall be repaired at his expense prior to submittal of final estimate for payment.

4. **The contractor shall verify with the Engineer at the start of the project that all required permits have been obtained.**

5. The contractor shall take adequate measures at all times to prevent demolition debris and erosion of soils from entering adjacent properties and streets.

6. The contractor shall provide a minimum of 4" of clean top-soil, fine graded over the area disturbed upon completion of all demolition and removal. Fine grading shall be done to bring property back to grade with existing surrounding properties and to ensure proper drainage. Fine grading shall be inspected and approved by the Engineer prior to placing grass seed and straw.

7. Unless otherwise stated herein, all work shall be done in accordance with these technical specifications and the Department of Engineering Standard Specifications. A copy of the Standard Specifications shall be obtained from the Engineering Department at a cost of \$15.75. Contractor shall have a copy of the current Standard Specifications **prior to submitting a quote**, and the copy **must be kept on the job site at all times**.

8. The Contractor shall type on his final estimate for payment the following statement:

“I certify this final payment to be just and true for work performed by (Contractor Name) and upon receipt of Balance Due, do hereby release the City of Newport News for all liabilities, obligations and claims upon Contract No. _____.”

9. A Right of Way permit is required for all demolition projects and shall be obtained from the Department of Engineering on the 8th floor of City Hall. The demolition project of Old Nicosia's Restaurant, to include removal of the parking lot, has address of 3114 Terminal Avenue, requires a Land Disturbance and Erosion Control agreement and \$75.00 fee since the area to be disturbed will be more that 2,500 square feet but less than 10,000 square feet.

10. **Sewer Cap Inspection Requirements:** In response to problems identifying sewer cap locations after demolition activities, new requirements have been adopted by the Department of Codes Compliance. It is the Contractors responsibility to determine which condition exists for each property. ***Codes Compliance is now allowing the contractor on Engineering administered demolition projects to fulfill this requirement during the demolition process instead of prior to demolition.***

The projects **with existing clean-outs** require the installation of a permanent cap or pipe plug within three (3) feet of the cleanout on the house side of the lateral. Flow-able fill (quikrete, etc.) is no longer an acceptable method of capping the sewer lateral. The demolition contractor will be permitted to perform this phase of the project with existing clean-outs. The Engineering Inspector will be permitted to witness the capping or plugging of lateral only for existing clean-out situations and shall forward confirmation of sewer lateral capping to Codes Compliance

The projects **without existing clean-outs** require the Contractor to employ a **Licensed Plumber** to perform all necessary plumbing work and contact Codes Compliance for all inspection requirements. ***Contractor possession of a HIGHWAY HEAVY license does not allow a contractor to obtain this permit.*** Sanitary sewer shall be located at right of way. Contractor is responsible for the installation of and maintaining appropriate barricades around excavation until a Codes Compliance Plumbing Inspector approves work and excavation is filled. A Licensed Plumber shall cut the sanitary sewer, install a combination wye, and bring the clean-out to ground level. The house side of combination shall have a permanent cap or plug installed. Joints underground shall be solvent weld or a shielded fernco type coupling. A cast iron clean-out box shall be installed at ground level around clean-out. All work shall be inspected and approved by a Codes Compliance Plumbing Inspector prior to filling excavation.

(See end of these specifications for sketches illustrating these requirements)

11. Allotted time for 10-day or 20-day notifications, if required for the demolition, has been added to the length of the time to complete the project. Also added to the length of the project is the time to address the sewer cap requirements and removal of any asbestos containing material (ACM) as identified per these specifications. *Therefore*, the structure, lot, and area of Old Nicosia's Restaurant (inclusive of the restaurant parking lot), **3114 Terminal Avenue**, shall be completely demolished, the site cleared, graded and seeded within **19 (nineteen)** days, excluding Sundays and Holidays, from the "Notice to Proceed". Liquidated damages of \$300.00 per calendar day will be assessed for each day that the contract is not completed within the time frame indicated.

12. **Permit fees will not** be assessed by the Department of Codes Compliance for this NNRHA demolition project located at 3114 Terminal Avenue. Plumbing permit for the clean-out installation, if required per Item #10 if this section, shall be obtained by a Licensed plumber with permit fee waived.
13. Contractor shall contact the Department of Engineering for final inspections for contractual requirements and shall also contact the Department of Codes Compliance for final inspections required for permits obtained from Codes for the demolition project.
14. Contractor shall not leave structures partially demolished overnight. Safety concerns shall not allow for this condition to exist in the demolition process of residential structures.
15. No work on these projects shall be subcontracted, **i.e., , demolition, asbestos abatement, plumbing, etc.,** without prior written notification and approval from the Department of Engineering. Any work performed by a subcontractor prior to the General Contractor obtaining written approval from the Department of Engineering will result in non-payment for that portion of work done.
16. Contractor shall be responsible for all submittals per 40 CFR part 61, subpart M- National Emission Standard for Hazardous Air Pollutants (NESHAP) and these specifications. When submittals are required Contractor shall send written notice by facsimile or certified mail, return receipt, for demolition work being performed to the following within ten (10) days of notice of intent to award and submit copies of these notices to the Engineer.

Asbestos Control Clerk
 Department of Labor and Industry
 Powers-Taylor Building
 13 South Thirteenth Street
 Richmond, VA 23219

Asbestos NESHAP Coordinator
 3WC32
 U.S. EPA, Region III
 1650 Arch Street
 Philadelphia, Pa 19103

17. Contractor shall schedule a site meeting with the Project Inspector for the “walk-through” of the project. This requirement shall take place prior to the issuance of the Notice to Proceed (NTP) and is for field verification of pre-existing damages to all right-of-ways, i.e., sidewalks, drive-way aprons, etc. and to determine route of access to property. Project Inspector is available to answer questions or concerns the Contractor may have pertaining to the project. Contractor shall not mobilize any equipment onto the project site until the NTP is in the Contractor’s possession as is reiterated in Special Construction Conditions (SCC), Item #20 and #21, and the “walk-through” requirement has been fulfilled. Failure of Contractor to schedule the “walk-through” shall cause Contractor to be responsible for any/all damages regardless of whether damages are pre-existing. Final payment will not be made until damages are repaired and/or replaced.

18. Contractor is responsible for removal and legal disposal of all personal property from within the structure, Old Nicosia's Restaurant, 3114 Terminal Avenue, demolition of the structure and removal of restaurant parking lot, removal and legal disposal of all debris, and clearing, grading and seeding of the areas disturbed per these specifications.
19. All utility disconnects for this demolition project(s) have been submitted to the appropriate utility companies with confirmations of disconnection being forwarded to the Department of Engineering. The demolition process has been started by Engineering by requesting the property measurements. Land Disturbance permit/agreement and fee requirements have also been determined. When all utility disconnects have been received and the City Attorney's Office has approved all insurances/bonds required of and submitted by the contractor, a Notice to Proceed (NTP) shall be prepared by the Department of Engineering. The NTP and utility disconnects and other pertinent information needed to obtain the required permits for the demolition project will be placed in a folder at the reception area of the Department of Engineering, 8th floor of City Hall, ready to be picked up by the Contractor prior to the start date on the NTP. Contractor shall be notified by the Department of Engineering when the NTP is ready to be picked up.
20. **Contractor shall not enter properties for any demolition activities nor will contractor mobilize any equipment onto the project site until a "Notice to Proceed" is in the Contractors possession and a contract or purchase order has been issued.**
21. Codes Compliance is now allowing the contractor on Engineering administered demolition projects to fulfill the Sewer Cap Requirement, SCC, Item #10, during demolition instead of prior to demolition. Demolition permit will be issued to the contractor by Codes Compliance with the understanding that FINAL payment shall not be made until this requirement is satisfactorily completed. All necessary submittals and permits shall be verified by the Engineer, Miss Utility shall have been contacted, and the NTP shall be in possession of the contractor prior to contractor mobilizing equipment onto the site.

PART I

ENVIRONMENTAL INFORMATION AND REQUIREMENTS

ASBESTOS-CONTAINING MATERIALS (ACM)

Contractors shall not compact demolition debris by continually running over the rubble with heavy equipment in order to create fewer loads of debris. This practice renders ACM friable and would require disposal of all debris from the site as friable asbestos.

Contractor shall call for an inspection of abatement work prior to demolishing any structure requiring removal of ACM. Failure to call for an inspection prior to demolition will result in non-payment for any and all work done for that particular structure.

Demolition projects identified requiring removal of asbestos-containing materials (ACM) prior to the start of demolition activities will be given up to five (5) days for the removal. Length of time allocated is dependent upon the amount identified during the survey. This allotted time is included within the time frame to complete the entire project as identified in SCC, Item #11.

An asbestos survey has been conducted of 3114 Terminal Avenue. Nothing was identified for removal prior to the start of the demolition of 3114 Terminal Avenue. Therefore no time has been added to this project for removal of ACM.

Roofing material and floor tiles have been assumed to be ACM. All roofing material and floor tiles are considered Category I Non-Friable ACM in good condition and will be left in place during demolition. Contractor assumes ownership of all debris generated from the demolition of the structures with building debris disposed of in a landfill that is permitted to accept Category I Non-Friable ACM.

Contractor, per the NESHAP, 40 CFR Part 61, subpart M, shall be responsible for the proper removal and legal disposal of all ACM identified for removal prior to demolition and any undetected ACM found during demolition. *If the demolition contractor should detect any suspicious materials during the demolition process he shall immediately stop work and notify the Department of Engineering.*

All ACM waste generated from this/these projects shall be disposed of in a landfill permitted to accept Category I Non-Friable ACM, Category II Non-Friable ACM or an E.P.A approved landfill for disposal of Friable ACM. Final payment shall not be made until a waste shipment record has been received by the City to verify proper disposal. Contractor shall be responsible for complying with State and Federal laws. The following regulations are incorporated into these specifications in their entirety:

29 CFR 1926.1101 - Revised OSHA Asbestos Standard for Construction

40 CFR part 61, subpart M - National Emission Standard for Hazardous Air Pollutants (NESHAP)

OTHER ENVIRONMENTAL CONCERNS

Contractor shall be responsible for the reclaiming of all refrigerants within the HVAC systems that may be a part of this structure to be demolished. Contractor shall be in compliance with all Federal and State Regulations at all times. Contractor shall submit certification that states either all refrigerants were reclaimed or none was present at the project sites. *Final payment shall not be authorized until such certification has been received.*

Contractor shall be aware that if any underground tanks are found the Contractor shall be responsible for removal of any product found in the tank and the removal and disposal of the tank. Payment for the product removal will be actual invoice plus **10** percent. Tank removal payment will be \$.50 per gal/tank size for tank sizes up to **1500** gallons. Example would be: \$.50 per gal/tank size @ 500 gallon tank = \$250.00. Tank sizes above **1500** gallons will be removed at a cost that will be negotiated prior to removal and disposal.

Contractor shall also be aware that due to the age of these structures there is the possibility of the presence of **lead-based paint**. Should the Contractor desire to take samples, all sampling shall be accomplished at no cost to the City and in the presence of a Virginia Lead licensed Department of Engineering staff member or a Virginia licensed Lead Inspector. All Toxicity Characteristic Leaching Procedure (**TCLP**) sampling, if required, will be done by licensed Department of Engineering staff at City expense. It shall be the responsibility of the Contractor to be in compliance with all Federal and State regulations during the entire demolition process at no additional cost to the owner. The following regulations are incorporated into these specifications in their entirety:

29 CFR 1926.62 – Lead Exposure in Construction

29 CFR 1910.1025 – Lead Exposure in General Industry

PART II

GENERAL CONDITIONS

BUILDING DEMOLITION/SITE DEMOLITION

GENERAL DEMOLITION

1. The Work involved in the Demolition and Site Clearance activities, under this contract, includes demolition, removal, and disposal off-site of all:
 - Structures
 - Foundation and Walls
 - Garages and Sheds
 - Concrete Slabs
 - Sidewalks
 - Rubbish, Trash, Junk, Tires
 - Underground Storage Tanks and Piping ** See Other Environmental Concerns
 - Aboveground Storage Tanks, Piping and Product
 - Vaults
 - Cesspools, Septic Tanks
 - Basements
 - Footers
 - Walls and Floors
 - Trees
 - Fencing
2. All rubbish, trash and junk (not otherwise identified) even though not a part of the demolished buildings, shall be removed and the site left clear of such materials.
3. Barricades around certain areas shall be erected as required by the Departments of Engineering and Codes Compliance. It shall be the responsibility of the Contractor to contact these departments to determine where barricades are required.
4. Electrical Services: ***Virginia Power has been notified*** that all electrical services should be disconnected from the subject buildings and site. The contractor shall be responsible for cutting off and disposing of all abandoned electrical cables to a depth of one foot below the surface of the ground.
5. Domestic Water Services: ***The Department of Public Utilities for the City of Newport News has been notified*** that water services to the subject buildings and site should be disconnected at the water meter. The contractor shall be responsible for cutting the existing water lines outside of the subject building and removing and disposing of all water lines within the entire complex.

6. **Miss Utility:** The contractor is responsible for contacting "Miss Utility of Virginia" by telephoning 1-800-552-7001, at least 72 hours prior to beginning work to demolish the existing building(s) and/or to perform the sewer cap requirements. Reference Special Construction Conditions, Item #10.
7. **Natural Gas Services:** *Virginia Natural Gas has been notified* that gas service should be disconnected. The contractor shall contact Miss Utility as a final check for natural gas service lines in the vicinity of the subject building.
8. **Telephone Services:** The contractor shall be responsible for cutting and disposing of all existing telephone service cables to a depth of one foot below the surface of the existing ground.
9. **Permits:** The contractor shall be responsible for obtaining all permits as required by the Departments of Codes Compliance and Engineering for the demolition of the subject structures and utilities. *See Special Construction Conditions item #12.*
10. The Contractor shall prevent or control to the satisfaction of the Department of Engineering, any dust that may result from any demolition operations. Hydrant meter application and information can be obtained on the internet by going to <http://www.nngov.com/waterworks/downloads/firehydrantmeterapplication> or by calling the Meter Shop, Lee Hall Maintenance & Operations Center, 425 Industrial Park Drive, 234-4913.
11. All structures, including buildings, sheds, platforms, steps, stoops, and all other accessory and incidental structures shall be demolished and removed off site.
12. All masonry walls and concrete slabs shall be demolished and removed off site. No concrete or masonry shall be permitted in material used for backfilling subsurface areas. The old Nicosia's Restaurant parking lot shall be removed as part of this project. Asphalt and concrete shall be removed to the sidewalk and/or driveway apron joints of the property. Concrete on north side of structure shall be removed to concrete joint approximately eight (8) feet from north side street curb.
13. **Three small trees** located at rear of structure along east perimeter of property shall be removed including the entire root ball.
14. All rubbish, debris, unstable and combustible material of every kind, including asphalt, wood, paper, tires, rags, and plaster, as well as incombustible material, including metal, and masonry will be removed from the area during the process of the work. Upon completion of the work, the site will be free of all debris except material used for backfilling.
15. No person who is not on the Contractor's payroll may be allowed on the site and/or engage in work covered by this Agreement.

16. No burning shall be permitted on the site. All combustible materials shall be disposed off site by the Contractor in accordance with all local regulations.
17. All structures are to be demolished on site and not sold to other parties, without specific, written approval by the City.
18. It shall be the responsibility of the Contractor to determine if there is an adequate disposal area for the materials and debris resulting from the demolition operations.
19. The Contractor shall furnish all materials required for filling of subsurface areas including basements, cellars, wells, cesspools/septic tanks and all other holes or depressions to the existing grade level. Fill materials shall be of a quality acceptable to the Engineer. Sufficient quantities of acceptable fill shall be on hand to ensure uninterrupted progress in completing the backfilling of all subsurface areas.

SPECIAL TRAFFIC CONDITIONS

1. The contractor shall not block any street at any time.
2. The contractor shall restore/repair any right-of-way damages during the demolition. Any damages shall be repaired by the contractor at his expense prior to submittal of final invoice. **See Item #17 of Special Construction Conditions.**
3. The contractor must obtain a right-of-way permit and provide traffic control and signage to direct vehicular and pedestrian traffic as needed or required by the Department of Engineering.

BACKFILLING AND GRADING

1. The demolition of all structures shall be complete and all subsurface areas within the limits of the contract shall be completely cleared of all unstable or combustible material before any backfilling operations begin.
2. The contractor shall furnish at his expense, any and all additional materials required for filling subsurface areas. Said materials shall be of a quality acceptable to the Department of Engineering.
3. No unstable or combustible materials such as wire, plaster, wallboard, wood, roots or other deleterious material and debris that would prevent proper consolidation and compaction or that will cause subsequent settlement will be permitted in the fill. Any material encountered during the demolition process which the contractor might propose to use as fill shall be stockpiled away from all demolition debris and shall be approved by the Department of Engineering prior to use.
4. No masonry shall be permitted in any fill.
5. The surface area disturbed for the project, including areas of overgrowth, shall be free of all debris, brick, concrete, tires, stone, wood, roof shingles, metal, all demolition debris, etc., *larger than 2-inches in any dimension*, upon completion.
6. Once the site has been cleared it shall be the responsibility of the contractor to bring the grade level with existing surrounding properties.. Contractor shall grade so as to leave the site free of any ponding or standing water. Grading shall be accomplished so as to achieve proper drainage.
7. Fine grading shall be inspected and approved by the Engineer prior to placing grass seed. Upon completion of fine grading, with a minimum of 4" of clean top-soil, the area disturbed for the project shall be covered with seed and straw. Hydro-seeding may be used in place of seeding and straw.
8. The contractor shall adhere to all erosion control regulations and must obtain a land disturbing permit or agreement as required by the Department of Engineering if the area to be disturbed is equal to or greater than 2,500 square feet. **See Special Construction Conditions Item #9.**

SEEDING

GENERAL

1.1 DESCRIPTION OF WORK

The Contractor shall furnish all labor, supervision, material, tools, equipment, supplies, and services; and, shall perform all Work necessary for providing and applying fertilizer, lime, seed and mulch in the quantities specified for areas designated on the Drawings or selected by the Engineer.

1.2 Seed:

- A. Seeds shall comply with applicable state and federal seed laws and the Contract Documents.
- B. Seed shall be subject to inspection by the Virginia State Seed Regulatory Inspectors of the Virginia Department of Agriculture and Consumer Services.
- C. Seed test shall be completed within the twelve-month period prior to the time the seed is to be used.
- D. Seed shall not be, or have been, stored in an enclosure where herbicides, kerosene, or other material detrimental to seed germination is stored.
- E. Noxious weed seeds, as defined by the rules and regulations adopted for enforcement of the Virginia Seed Law, will not be permitted. The number of restricted noxious weed seeds shall be not more than the number per ounce or per pound of noxious weed seeds specified in the rules and regulations.

Schedule of Grass Seed Mixture and Application Dates:

Date	Proportion by Weight	Common Name	Botanical	Min. % Germ.	Min. % Pure Sd.	Max. % Weed Sd.
March 1 - Nov. 15	100%	Fescue	Festuca arundinacea	85	98	0.25
Nov. 16 – Feb. 28	100%	Annual Rye Grass	Lolium multiflorum	90	95	0.15

Fertilizer:

- A. Fertilizer shall be uniform in composition, free flowing, and suitable for application with approved equipment.

- B. Ureaformaldehyde shall be slow-release fertilizer material containing 38 percent nitrogen. The material shall have an activity index of 40 to 50 percent as determined by tests in accordance with the Association of Official Agricultural Chemists.
- C. Fertilizer for general seeding shall be Grade 15-30-15 fertilizer, uniform in composition, free flowing, and suitable for application with approved equipment, and shall be applied at the rate of 600 lb/acre (unless specified otherwise by soil tests).

Lime

- D. Lime shall be agricultural grade ground limestone. Agricultural grade pulverized limestone may be used at no additional cost to the Owner.
- E. The material source shall be registered with and approved by the Virginia Department of Agriculture and Consumer Services in accordance with the Virginia Agricultural Lime Law and shall conform to the following requirements:
- F. Ground limestone shall be of such fineness that at least 86 percent will pass a No. 20 mesh screen, at least 47 percent will pass a No. 60 mesh screen, and at least 28 percent will pass a No. 100 mesh screen. Material shall have a calcium carbonate equivalent of at least 85 percent.
- G. Pulverized limestone shall be of such fineness that at least 90 percent will pass a No. 20 mesh screen and at least 66 percent will pass a No. 100 mesh screen. Material shall have a calcium carbonate equivalent of at least 85 percent.

Mulch:

- H. Mulch for seeding (vegetative) shall consist of dry straw, free from noxious weeds. Mulch shall be reasonably bright in color and shall not be musty, moldy, caked, decayed, or very dusty.

1.3 ****SUBMITTALS** (New)**

Prior to use or placement, the Contractor shall submit certifications in the form of affidavits from the material suppliers, together with supporting data, attesting that the composition of lime, fertilizer, seed and mulch meet specification requirements.

EXECUTION

2.1 PROCEDURES

- I. Seeding operations shall not be performed when the ground is frozen or when soil or weather conditions would prevent proper soil preparation and subsequent operations. When hydroseeding is performed, nozzles or sprays shall not be directed toward the ground in a manner that will cause erosion or runoff. The Contractor shall notify the Engineer at least 48 hours prior to beginning seeding operations.
- J. Lime shall be uniformly applied to areas to be seeded at the rate of 2 tons per acre (unless specified otherwise by soil tests). Any approved method may be used.
- K. After lime has been applied, areas to be seeded shall be prepared as follows: Slopes 3:1 or flatter shall be loosened to a depth of approximately 3-inches by disking, harrowing, or other approved methods. Loosening of soil on excavated slopes steeper than 3:1 will not be required except to eliminate hard or crusted surfaces. Shoulders and embankment slopes steeper than 3:1 shall be loosened to a depth of approximately 1-inch. Clods, loose stones, and other foreign material larger than 2-inches in any dimension shall be removed and properly disposed of as approved by the Engineer. Gullies, washes, and disturbed areas that develop subsequent to final stabilization shall be repaired before they are seeded.
- L. When dry fertilizer is used, it shall be applied uniformly to the seeding areas at the time of seeding at the rate of 600 pounds of 15-30-15 fertilizer, or an equivalent 1-2-1 fertilizer, per acre (unless specified otherwise by soil tests). The method of application shall be approved by the Engineer before fertilizer is applied.
- M. When in a liquid form or mixed with water, fertilizer shall provide the same value of nutrients per acre as specified for dry fertilizer. Fertilizer applied in liquid form shall be agitated during application.
- N. Seed shall be uniformly applied on prepared areas with fertilizer and mulch and shall conform to the following:
 - 1. For hydroseeding, seed shall be put in the mixture slowly to result in a uniform mixture before application. Hydroseeding mixtures shall be constantly agitated from the time of mixing until application on the seed bed and used within 8 hours from the beginning of mixing.
 - 2. Overseeding shall consist of applying seed and fertilizer on areas prepared as directed by the Engineer.

- O. Mulch shall be applied within 48 hours after completion of the seeding operation. When straw mulch is used, it shall be applied on seeded areas at the rate of approximately 2 tons per acre. When wood cellulose fiber mulch is used, it shall be uniformly applied at the rate of approximately 1,500 pounds (net dry weight) per acre. Mulch will not be required on overseeded areas.
- P. Straw mulch shall be applied to a uniform thickness in such a manner that not more than 10 percent of the soil surface will be exposed. Wet straw shall not be used. Straw mulch shall be anchored to the seeded surface by spraying with wood cellulose fiber at the rate of 750 pounds per acre; spraying with an emulsified asphalt at the rate of at least 100 gallons per ton to mulch in a manner that will protect adjacent property and pedestrian traffic areas; disking or punching the mulch partially into the soil; using approved netting; or, using other materials or methods approved by the Owner. The Contractor may use more than one method on the same project.

2.2 ESTABLISHMENT AND MAINTENANCE

- A. Areas not showing signs of grass growth shall immediately be reseeded. Protection shall be provided against traffic or other use by erecting barricades, as needed, immediately after treatment is completed, and by placing warning signs, as directed. The Contractor shall assume responsibility for proper care of seeded areas while grass is becoming established for three months after completion of treatment on the entire project, unless desired cover is established in a shorter period of time (desired coverage shall be 90% of total area seeded). When any portion of the surface becomes gullied or otherwise damaged or treatment is destroyed, the affected portion shall be repaired to re-establish condition and grade of soil and treatment prior to injury, as directed. Repair work shall be performed without additional cost.
- B. Mulched areas shall be maintained until all work or designated portions thereof have been completed and accepted. Any damage shall be repaired, and mulch materials that has been removed by wind or other causes shall be replaced and secured.

2.3 CLEANUP AND PROTECTION

- A. The Contractor shall keep pavements clean and work area in an orderly condition.
- B. The Contractor shall protect existing landscape work and materials from damage due to landscape operations, operations by other contractors and trades and trespassers; and, shall maintain protection during installation and maintenance period of three (3) months.

SEWAGE COLLECTION SYSTEMS DRAWING 1

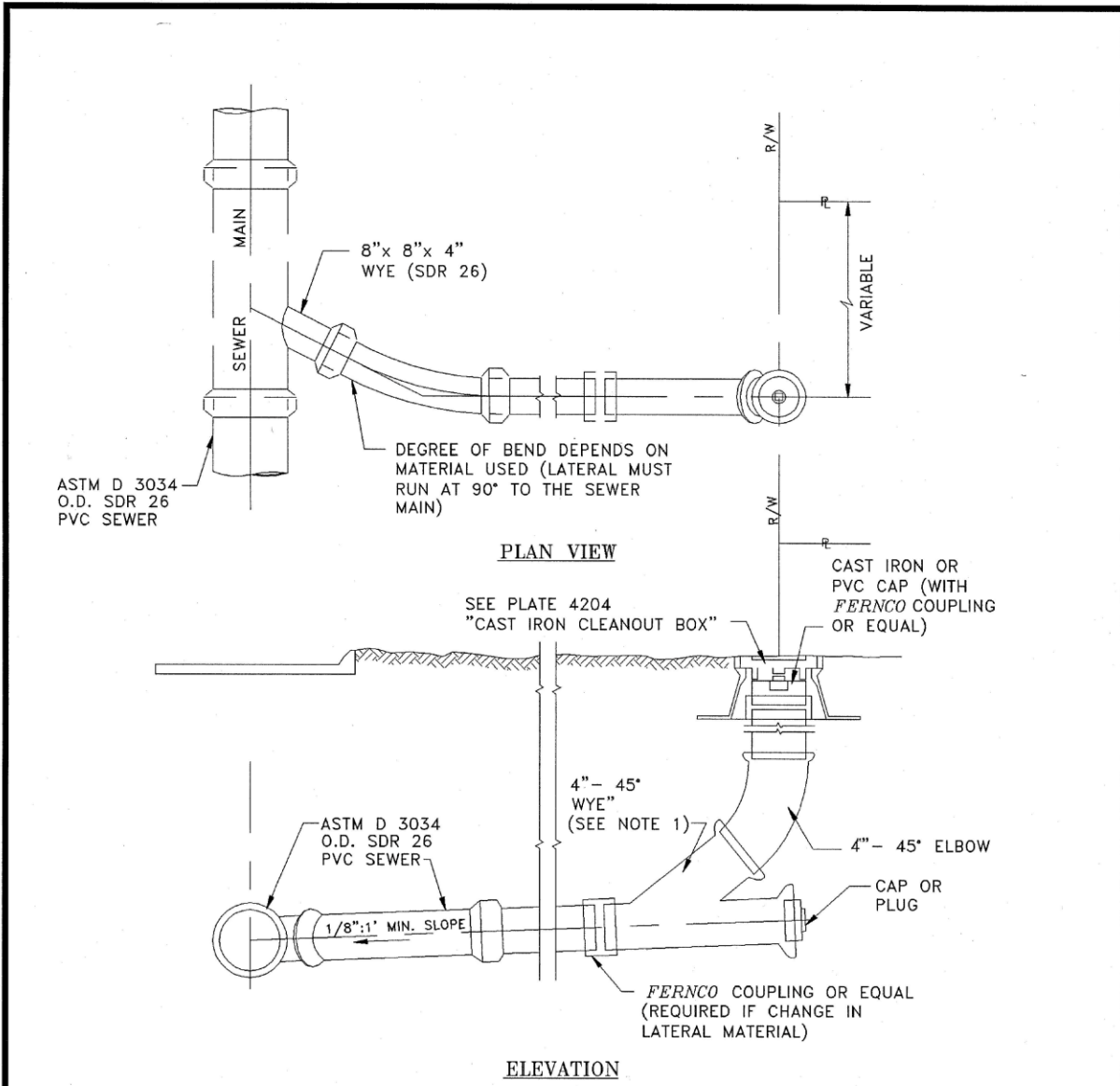

NOTES:

1. Lateral pipe shall be SDR 26, unless due to special circumstances the Director requires the pipe to be ductile iron (D.I.). In either case, the wye (4" x 4" x 4") pipe used in conjunction with the cleanout box may be SDR 35.5 until an SDR 26 wye becomes available in the manufacturing industry.
2. Also see Plate 4202 "Ductile Iron House Lateral for Deep Sewer Main."



Approved

August 1997

Mostafa A. Sabbah

MOSTAFA A. SABBABH, Ph.D., P.E.
Director, Department of Engineering

HOUSE LATERAL

Plate 4201

SEWAGE COLLECTION SYSTEMS DRAWING 2

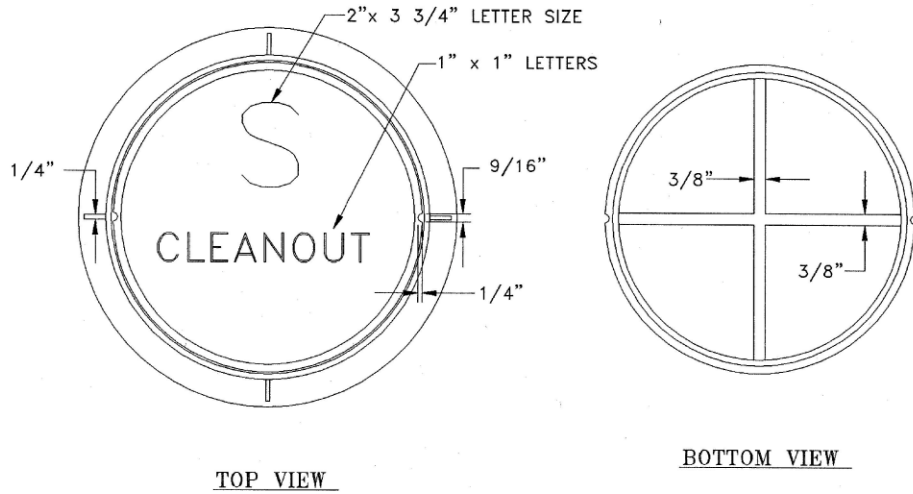

COVER

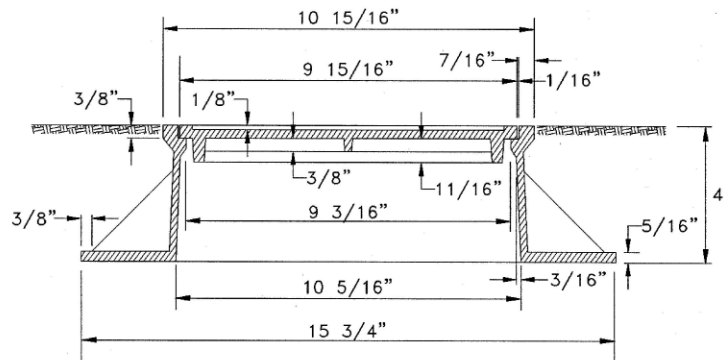

PROFILE



Approved

August 1997

Mostafa A. Sabbah
MOSTAFA A. SABBABH, Ph.D., P.E.
Director, Department of Engineering

CAST IRON
CLEANOUT BOX

Plate 4204