



Informal Request for Quotations

IRFQ #2010-4592-1905

February 3, 2010

City of Newport News Office of the Purchasing Director

2400 Washington Avenue

Newport News, VA 23607

Phone: (757) 926-8043 Fax: (757) 926-8038

www.nngov.com/purchasing

Demolition of 1120 37th Street for Code Compliance. – Pkg. #2 - 2010

Quotations, subject to the conditions and instructions contained herein, will be received at the above office of the Purchasing Agent, 4th Floor, City Hall, 2400 Washington Avenue, Newport News, Virginia, until the due date and hour shown below (local prevailing time), for furnishing the following described equipment, materials, and/or services, for delivery and/or performance F.O.B. NEWPORT NEWS, VIRGINIA.

Scope of Work – Removal and legal disposal of all asbestos-containing material, removal and legal disposal of all personal property from within the dwelling, demolitions the structures, removal and legal disposal of all debris, and clearing, grading and seeding of the area disturbed per these specifications.

Quotation Due: February 10, 2010 @ Close of Business

Contract Officer: _____

Michael Coburn, Sr., CPPO, Purchasing Administrator, mcoburn@nngov.com

This form must be signed. Initial all pages on the space provided, as well as subsequent addenda. All signatures must be original and not photocopies.

THE ORIGINAL "SECTION A" AND ONE DUPLICATE COPY IS REQUESTED

In compliance with this Request for Quotations, and subject to all the conditions thereof, the undersigned offers, if this quote is accepted within (60) calendar days from the date of the opening, to furnish any or all of the items and/or services upon which prices are quoted, at the price set opposite each item, to be delivered at the time and place specified herein. The undersigned certifies he has read, understands, and agrees to all terms, conditions, and requirements of this quote, and is authorized to contract on behalf of firm named below.

This Public Entity does not discriminate against faith-based organizations.

Company Name: _____

Address: _____

City/State/Zip: _____

Telephone: _____ Fax No.: _____

Email: _____

Print Name: _____ Title: _____

Signature: _____ Date: _____

(This Form Must Be Signed)

TABLE OF CONTENTS

Request for QuotationCover Page

Table of ContentsTC-1

Section A

Conditions and InstructionsC&I-1 thru C&I-11

 Notice to Contractors.....NTC-1

Quote.....Q-1 thru Q-4

Section B

Insurance Endorsement.....INS-1 thru INS-4

Performance BondPB-1 thru PB-3

Labor and Material Payment Bond.....LMB-1 thru LMB-4

Section C

Special Construction Conditions.....SCC-1 thru SCC-4

Environmental Information & RequirementsE-1 thru E-2

 General Conditions.....GC-1 thru GC-3

Special Traffic ConditionsSTC-2

Backfilling, Grading & Seeding5 Pages

Sewer Cap Illustrations.....2 Pages

Section A

CONDITIONS AND INSTRUCTIONS

1. **All quotes must be submitted on and in accordance with this form. All quotes must be submitted, sealed, plainly marked using the quote number, due date and time.**
2. **Availability of Funds:** A contract shall be deemed executory only to the extent of appropriations available to each department for the purchase of such articles or services. The City's extended obligations on those contracts, which envision extended funding through successive fiscal periods shall be contingent upon actual appropriations for the following years.
3. By signing this quotation, the service provider assigns to the City of Newport News any and all rights that he may have under the antitrust laws of the United States and the Commonwealth of Virginia in any way arising from or pertaining to this quote. This provision is remedial in nature and is to be liberally construed by any court in favor of the City of Newport News.
4. **Appeals Procedure:** Upon request administrative appeals information will be provided which shall be used for hearing protests of a decision to award or an award, appeals from refusal to allow withdrawal of quotes, appeals from disqualification's and determinations of non-responsibility and appeals from decision or disputes arising during the performance of a contract.
5. **Applicable Law and Courts:** Any purchase order/contract resulting from this solicitation shall be governed in all respects by the laws of the Commonwealth of Virginia and any litigation with respect thereto shall be brought in the courts of the Commonwealth. The contractor shall comply with applicable federal, state and local laws and regulations.
6. **Non-Discrimination: This Public Entity does not discriminate against faith-based organizations.** During the performance of this contract, the successful contractor agrees as follows:
 - a. He will not discriminate against any employees or applicants for employment because of race, religion, color, sex, national origin, age, disability, or any other basis prohibited by state law relating to discrimination in employment, except where one or more of these are a bona fide occupational qualification reasonable necessary to the normal operations of the contractor. The contractor agrees to post in conspicuous places available to employees and applicants for employment, notices setting forth the provisions of this non-discrimination clause.
 - b. The contractor will be and state that he is an equal opportunity employer in all solicitations or advertisements for employees.
 - c. Notices, advertisements and solicitations placed in accordance with federal law, rule or regulation shall be deemed sufficient for the purpose of meeting the requirements of this section.

The contractor will include the provisions of the foregoing paragraphs (a), (b) and (c) in every subcontract or purchase order of over ten thousand dollars so that the provisions will be binding upon each subcontractor or vendor.

During the performance of this contract, the contractor agrees to (i) provide a drug-free workplace for the contractor's employees; (ii) post in conspicuous places, available to employees

and applicants for employment, a statement notifying employees that the unlawful manufacture, sale, distribution, dispensation, possession, or use of a controlled substance or marijuana is prohibited in the contractor's workplace and specifying the actions that will be taken against employees for violations of prohibition; (iii) state in all solicitations or advertisements for employees placed by or on behalf of the contractor that the contractor maintains a drug-free workplace; and (iv) include the provisions of the foregoing clauses in every subcontract or purchase order of over \$10,000, so that the provisions will be binding upon each subcontractor or vendor.

For the purposes of this subsection, "drug-free workplace" means a site for the performance of work done in connection with a specific contract awarded to a contractor in accordance with this subsection, the employees of whom are prohibited from engaging in the unlawful manufacture, sale, distribution, dispensation, possession or use of any controlled substance or marijuana during the performance of the contract.

7. **Direct contact with City departments other than Purchasing on the subject of this bid is expressly forbidden except with the foreknowledge and permission of the Director of Purchasing or his representative.**
8. It is the policy of the City of Newport News to facilitate the establishment, preservation, and strengthening of small businesses and businesses owned by women and minorities and to encourage their participation in the City's procurement activities. Toward that end, the City encourages these firms to compete and encourages non-minority firms to provide for the participation of small businesses and businesses owned by women and minorities through partnerships, joint ventures, subcontracts, and other contractual opportunities. The provider is required to include a statement indicating the planned use of such businesses in fulfilling this contract.

The City provides a directory of Newport News Minority and Women-owned businesses on our website at no additional cost.

9. Quotes and amendments thereto, if received by the City after the date and time specified for the solicitation opening, will not be considered. It will be the responsibility of the service provider to see that their quote is in the Purchasing Office by the specified time and date. If City Hall is closed for business at the time scheduled for opening, for whatever reasons, sealed bids will be accepted and opened on the next business day of the City, at the originally scheduled hour. There will be no exceptions. Date of postmark will not be considered. Telephone, facsimile and quotes will not be accepted.
10. Unless qualified by the provision "NO SUBSTITUTE", the use of the name of manufacturer, brand, make or catalog designation in specifying an item does not restrict providers to the manufacturer, brand, make or catalog designation identification. This is used simply to indicate the character, quality and/or performance equivalence that it will serve as that specified. In submitting quotes on a commodity other than specified, the service provider shall furnish complete data and identification with respect to the alternate commodity offered.

Consideration will be given to quotes submitted on alternate commodities to the extent that such action is deemed to serve the best interests of the City. If the provider does not

indicate that the commodity proposed is other than specified, it will be construed to mean that the provider proposes to furnish the exact commodity described.

11. Award will be made to the lowest responsive and responsible provider as determined by the LUMP SUM PRICE. The quality of the articles to be supplied, their conformity with the specifications, their suitability to the requirements of the City, and the delivery terms will be taken into consideration in making an award. Length of time for delivery as well as price may be considered in awarding the quote.
12. The City reserves the right to award by line item, groups of items or total quote; to reject any and all quotes in whole or in part, and to waive any informality if it is determined to be in the best interest of the City to do so.
13. Notice of award is not to be construed to be "Notice to Proceed". The City will schedule a preconstruction meeting to review the work plan, receive the submittals as may be required including bonds, insurance, permits, etc. A formal "Notice to Proceed" will be given which shall start the time for which the Contractor is responsible for completion of the project.
14. **Special Note:** The successful contractor shall furnish all required bonds, certificates of insurance and required endorsements on City approved forms included in this bid package. Any other forms are not acceptable and shall not be approved by the City Attorneys office. Time is critical on this work and non-compliance will delay the work and may be cause to make award to the next qualified contractor.
15. **Engineering Standard Specifications:** This contract consists of plans, technical specifications and Department of Engineering Standard Specifications. The Standard Specification are available for \$15.75, including tax, per copy non-refundable, from the Department of Engineering, City Hall Building, 8th floor, Newport News, Virginia 23607, telephone (757) 926-8611. In the Standard Specification any/all references to the Director of Engineering, which involves the initial Request for Quotation and prior to an actual contract being awarded shall be defined and interpreted as the City's Purchasing Director or his designee.
16. **Liquidated Damages:** TIME IS OF THE ESSENCE ON THIS CONTRACT. Failure of the Contractor to complete the work within the time allowed will result in damages being sustained by the City. Such damages are, and will continue to be, impracticable and extremely difficult to determine. For each consecutive calendar day in excess of the time specified for completion of the work at each site, the Contractor shall pay to the City, or have withheld from monies due it, the sum of **\$300.00**. Execution of the contract under these specifications shall constitute agreement by the City and Contractor that this amount per day is the minimum value of the costs and actual damage caused by failure of the Contractor to complete the work within the allotted time, that such sum is liquidated damages and shall not be construed as a penalty, and that such sum may be deducted from payments due the Contractor if such delay occurs. Permitting the Contractor to continue and finish the work or any part thereof after the contract time or adjusted contract time, as pertinent, has expired shall in no way operate as a waiver on the part of the City or any of its rights under the contract.

Payment of liquidated damages shall not release the Contractor from obligations in respect to the fulfillment of the entire contract, nor shall the payment of such liquidated damages constitute a waiver of the City's right to collect any additional damages which may be sustained by failure of the Contractor to carry out the terms of the contract, it being the intent of the parties that said liquidated damages be full and complete payment only for failure of the Contractor to complete the work on time.

17. **Silence of Specifications:** The apparent silence of these specifications and any supplemental specifications as to any detail or the omission from the specifications of a detailed description concerning any point shall be regarded as meaning that only the best commercial practices are to prevail and correct type, size and design are to be used. All interpretations of these specifications shall be made on the basis of this statement.
18. The contractor shall keep himself fully informed of all Federal, State and local laws, ordinances and regulations that in any manner affect the conduct of the work. The contractor shall at all times observe and comply with all such laws, ordinances and regulations and he shall protect and indemnify the City, and its representatives against any claim or liability arising from or based on any violation of the same, whether by the contractor, his subcontractors, suppliers of materials or services, or others engaged by the contractor or the employees of any of them. **The contractor certifies that he does not and will not during the performance of this Contract violate the provisions of the Federal Immigration Reform and Control Act of 1986, which prohibits employment of illegal aliens.**
19. **Contractor's License:** If a contract is for seventy thousand dollars (\$70,000) or more, or if the total value of all construction, removal, repair of improvements undertaken by the contractor within any twelve-month period is three hundred thousand dollars (\$300,000) or more, the contractor is required under Title 54.1, Chapter 11, Code of Virginia (1950), as amended, to show evidence of being licensed as a "Class A Contractor". If a contract is fifteen hundred dollars (\$1,500) or more but less than seventy thousand dollars (\$70,000), the contractor is required to show evidence of being licensed as a "Class B Contractor".

Contractors who qualify for license as a "Class C" certificate will be authorized to do jobs in the range of \$1,000-\$7,500. Electrical, plumbing and heating \ ventilation \ air conditioning contractors are not eligible for Class C. A valid business license from the City may be required. The provider shall complete whichever of the notations is appropriate:

"Licensed Class A Virginia Contractor No. _____."

"Licensed Class B Virginia Contractor No. _____."

"Licensed Class C Virginia Contractor No. _____."

"Contract is less than \$1,500 therefore licenser is not required under Title 54, chapter 7, Code of Virginia (1950) as amended."

20. **Bid Bond:** A bidder's bond or certified check in the amount of five percent (5%) of the

amount bid shall accompany any bid in excess of \$100,000 for the bid to be considered.

21. **Performance and Labor and Material Payment Bond:** The Contractor may be requested to furnish within ten (10) calendar days of notice of intent to award, a performance bond and a labor and material payment bond, (use only forms attached to bid unless approved by City Attorney) in the amount of the contract price as security for faithful performance of the work in strict conformity with the Contract Documents and for payment of all persons who perform labor and furnish materials in prosecution of the work. The surety on such bonds shall be duly authorized to do business in the Commonwealth of Virginia and satisfactory to the City.
22. **Permits:** Permit fees for Codes Compliance are waived but Engineering permit fees are assessed. Contractor shall be responsible for furnishing and paying for all necessary permits as required by the City of Newport News prior to start of construction. Proof of approved final inspections shall be required before final payment is made.
23. **Insurance:** The Contractor shall maintain liability insurance, which shall protect and save harmless the City of Newport News, Virginia, and its officials from all suits and actions of every kind and description arising from injury or damage to persons and property in the prosecution of said work or in failure to properly safeguard same, and from all claims arising under the workmen's compensation laws. The Contractor shall furnish proof of said insurance prior to commencement of services. Separate forms, which name the City as additional insured and as alternate employer must be included with the Certificate of Insurance.

Effective 9/1/02, the City of Newport News shall require additional insurance for Third Party Jobsite Pollution and Hazardous Material liability insurance for all demolition projects. Proof of these insurances may appear as additional policies on the certificate of insurance or as endorsements to existing policies. In either case, the City of Newport News, C/O Purchasing Department 2400 Washington Ave, Newport News, VA 23607 shall be named as additional insured on EACH policy.

The Commonwealth of Virginia requires construction contractors and subcontractors to obtain and maintain worker's compensation insurance while performing work on behalf for the City. Evidence of coverage needs to be provided prior to commencement of work.

Sample forms CG 20-10 (naming the City as additional insured for liability claims) and WC 00-03-01 (naming the City as an alternate employer for Worker's Compensation claims); and the Commonwealth's form for Worker's Compensation Certificate of Coverage are attached (**see Section B**).

Contractor shall have ten (10) days from notice of intent to award to provide insurance documentation. Failure to provide the Certificate and forms within this period may be cause for the City to award a contract to the next responsive bidder, and hold the original Contractor liable for excess costs.

EXCEPTION PAGE

EXCEPTIONS:

Provider must sign the appropriate statement below, as applicable:

() Provider understands and agrees to all terms, conditions, requirements, and specifications stated herein.

Firm: _____

Signature: _____

() Provider takes exception to terms, conditions, requirements, or specifications stated herein (Provider must itemize all exceptions below, and return with this quotation):

Firm: _____

Signature: _____

Specify payment terms if other than "2%-20, Net 30"; _____

Payment terms shall be considered in determining the low bidder.

Providers should note that any exceptions taken from the stated terms and/or specifications may be cause for their submittal to be deemed "non-responsive", risking the rejection of their submittal.

Quotation Results

For a complete written tally sheet, please go to www.nngov.com/purchasing and find the solicitation. Bids should be posted within 24 hours of receipt of bids.

NOTICE TO CONTRACTORS

Quotations will be received by the Department of Purchasing of the City of Newport News, Virginia, on the 4th Floor, City Hall Building, 2400 Washington Avenue, no later than **February 10, 2010, at the Close of Business for the Demolition of 1120 37th Street for Codes Compliance Pkg. #2 - 2010.**

Please be advised that all technical or procedural questions in reference to this project must be directed to Michael Coburn, CPPO, of the Department of Purchasing via fax (757) 926-8038, and/or e-mail: mcoburn@nngov.com.

Scope of Work – Removal and legal disposal of all asbestos-containing material, removal and legal disposal of all personal property from within the dwelling, demolition of the structures, removal and legal disposal of all debris, and clearing, grading and seeding of the area disturbed per these specifications.

Each quote greater than \$100,000 shall be accompanied by a bidder's bond or a certified check of five percent (5%) of the amount of the quote. Performance and Labor & Material Payment Bond amounting to one hundred percent (100%) of the contract price may be required of the successful contractor.

This contract consists of plans, technical specifications and Department of Engineering Standard Specifications. **If the Contractor submitting a quote does not have a set of the current Department of Engineering Standard Specifications, a set SHALL BE PURCHASED prior to submitting a quote at a cost of \$15.75, including tax per copy, non-refundable and shall be maintained on the job site at all times until completion of the project.**

The attention of the provider is invited to the provision of Chapter 11 of Title 54.1 of the Code of Virginia regulating the practice of general contracting under which it will be necessary for the provider to show evidence of certificate of registration as provided by said code.

The City of Newport News reserves the right to reject any or all quotes.

Everett P. Skipper, P.E., B.C.E.E.
Director of Engineering
2400 Washington Avenue
Newport News, VA 23607

To The City Manager
City of Newport News
Newport News, Virginia

Dear Sir:

In submitting this quote, the undersigned declares that he is, or they are, the only person, or persons, interested in said quote, that it is made without any connection with any person making another quote for the same contract; that the quote is in all respects fair and without collusion, fraud or mental reservation; and that no official of the City, or any person in the employ of the City, is directly or indirectly, interested in said quote, or in the supplies or work in which it relates, or on any portion of the profits thereof.

The undersigned also declares that he had, or they have, examined all the specifications, specifically including the Standard Specifications, August 1, 1983, form of contract, and that he has, or they have, personally inspected the actual location of the work together with the local sources of supply and understands that in signing this quote, he, or they, waive all right to plead a misunderstanding regarding the same.

The undersigned further understands and agrees that he is, or they are, to furnish and provide for the respective item price quote, all necessary materials, machinery, implements, tools, labor, service, et cetera, and to do, and perform all the work necessary under the aforesaid conditions to complete the improvements aforementioned in accordance with the specifications for said improvements which specifications, it is agreed, are a part of this quote, and to accept in full compensation therefore, the Lump Sum price for each location.

QUOTATION

Furnish all labor, materials, equipment, and supervision necessary for the complete **demolition and removal of all structures, improvements and appurtenances as detailed in the specifications for:**

1. 1120 37th Street \$ _____ (Lump Sum Price)

Additional Pricing:

At times demolition projects lend themselves to uncertainties and discoveries not within the scope of work. The City reserves the right to require the successful contractor to provide a performance bond and labor and material bond before award of this project. The pricing will not determine the lowest responsive, responsible provider.

Price to furnish performance bond and labor and material bond: _____

NOTE:

1. The Contractor shall be responsible for visiting the project site to ascertain that his quote reflects the amount of work required for a complete functional project constructed in accordance with the intent of the project plans and specifications.
2. The Contractor shall be responsible for the adequacy of equipment submitted for use on the project.
3. Award of the contract shall be in accordance with Section 2-563 of the City Procurement Code and shall be based on the lump sum price as shown on Page B-2.
4. "Time is of the essence"; Therefore, the structures and lot listed in this contract shall be completely demolished, and cleared per specifications within seven (7) business days per structure, minus Sundays and Holidays after notice to proceed or liquidated damages of \$300.00 per day, including any part of a day, shall apply. "Notice to Proceed" shall not be given until all insurances and bonds have been reviewed and accepted by the City Attorney.
5. All work shall comply with the current City of Newport News Standards & Specifications.

ANTI-COLLUSION CERTIFICATION

The service provider certifies that this quote is made without prior understanding, agreement, or connection with any corporation, firm, or person submitting a quote for the same product and that this quote is in all respects bona fide, fair and not the result of any act of fraud or collusion with another person or firm engaged in the same line of business or commerce. The provider understands collusive bidding is a violation of Federal Law and that any false statement hereunder constitutes a felony and can result in fines, imprisonment, as well as civil damages. The service provider also understands that failure to sign this statement will make the quote non-responsive and unqualified for award.

Signed: _____ Date: _____

Name of Company: _____

On acceptance of this quote for said work, the undersigned does, or do hereby bind himself, or themselves, to enter into a written contract within ten (10) days of award, with the said City, and to give the required bond and surety to perform said work for the consideration above named.

The service provider agrees to complete the entire work within **seven (7) days per structure** minus Sundays and Holidays, from the "Notice to Proceed".

State Contractor License Number _____

Business Name: _____

Address: _____
(Street; PO Box not acceptable)

(City, State and Zip Code)

By: _____ Date: _____

By: _____ Date: _____

ADDENDA
No.

ACKNOWLEDGED
Initial

THE ORIGINAL SECTION A AND ONE DUPLICATE COPY IS REQUESTED. IF CONTRACTOR DESIRES TO MAKE ANY ALTERNATIVE QUOTE ON DIFFERENT TYPE OF CONSTRUCTION THAN ONE CALLED FOR, IT SHALL BE ENCLOSED ON A SEPARATE SHEET.

Section B

INSURANCE ENDORSEMENTS

Insurance The contractor shall maintain adequate liability insurance, which shall protect and save harmless the City of Newport News, Virginia, and its officials from all suits and actions of every kind and description arising from injury or damage to persons and property in the prosecution of said work or in failure to properly safeguard same, and from all claims arising under the workmen's compensation laws. The contractor shall furnish proof of said insurance prior to commencement of services. Separate forms which name the City as additional insured and as alternate employer must be included with the Certificate of Insurance. Original signatures (not photocopies) are required and binder numbers will not be accepted.

The Commonwealth of Virginia requires construction contractors and subcontractors to obtain and maintain worker's compensation insurance while performing work on behalf for the City. Evidence of coverage needs to be provided prior to commencement of work.

Sample forms CG 20-10 (naming the City as additional insured for liability claims) and WC 00-03-01 (naming the City as an alternate employer for Worker's Compensation claims); and the Commonwealth's form for Worker's Compensation Certificate of Coverage are attached.

Effective 9/1/02, the City of Newport News shall require additional insurance for Third Party Jobsite Pollution and Hazardous Material liability insurance for all demolition projects. Proof of these insurances may appear as additional policies on the certificate of insurance or as endorsements to existing policies. In either case, the City of Newport News, C/O Purchasing Department 2400 Washington Ave, Newport News, VA 23607 shall be named as additional insured on EACH policy.

Contractor shall have ten (10) days from notice of intent to award to provide insurance documentation. Failure to provide the Certificate and forms within this period may be cause for the City to award a contract to the next responsive bidder, and hold the original contractor liable for excess costs.

<u>TYPE INSURANCE COVERAGE</u>	<u>LIMITS</u>
1. Workman's Compensation Employer's Liability	Statutory \$100,000.00
2. Comprehensive General Liability with XCU & Contractual included	\$1,000,000.00 each \$1,000,000.00 each Occurrence
3. Property Damage Liability	\$100,000.00 each Occurrence
4. Jobsite Pollution	\$100,000.00 each Occurrence
5. Hazardous Material Liability	\$100,000.00 each Occurrence

POLICY NUMBER: _____

COMMERCIAL GENERAL LIABILITY
CG 20 10 10 93

THIS ENDORSEMENT CHANGES THE POLICY. PLEASE READ IT CAREFULLY.

**ADDITIONAL INSURED – OWNERS, LESSEES OR
CONTRACTORS (FORM B)**

This endorsement modifies insurance provided under the following:

COMMERCIAL GENERAL LIABILITY COVERAGE PART

SCHEDULE

Name of Person or Organization:

**City of Newport News
c/o Purchasing Department
2400 Washington Avenue
Newport News, VA 23607**

(If no entry appears above, information required to complete this endorsement will be shown in the Declarations as applicable to this endorsement).

WHO IS AN INSURED (Section II) is amended to include as an insured the person or organization shown in the Schedule, but only with respect to liability arising out of your ongoing operations performed for this insured.

CG 20 10 10 93

INS-2

Endorsement

Alternate Employer

WC 00 03 01

Policy Amendment

If the following information is not complete, refer to the appropriate information page attached to the policy.

INSURED	POLICY NO.	SEQ. NO.
PRODUCER	EFFECTIVE DATE	

SCHEDULE

Alternate Employer

Address

State of Special
or Temporary Employment

**City of Newport News, Purchasing Dept.
c/o Purchasing Department
2400 Washington Avenue,
Newport News, VA**

This endorsement applies only with respect to bodily injury to your employees while in the course of special or temporary employment by the alternate employer in the state named in the Schedule. Part One (Workers Compensation Insurance) and Part Two (Employers Liability Insurance) will apply as though the alternate employer is insured.

Under Part One (Workers Compensation Insurance), we will reimburse the alternate employer for the benefits required by the workers compensation law if we are not permitted to pay the benefits directly to the person entitled to them.

The insurance afforded by this endorsement is not intended to satisfy the alternate employers duty to secure its obligations under the workers compensation law. We will not file evidence of this insurance on behalf of the alternate employer with any government agency.

We will not ask any other insurer of the alternate employer to share with us a loss covered by this endorsement.

Premiums will be charged for your employees while in the course of special or temporary employment by the alternate employer.

Part Four (Your Duties If Injury Occurs) applies to you and the alternate employer. The alternate employer will recognize our right to defend under Parts One and Two and our right to inspect under Part Six.

WORKER'S COMPENSATION

CERTIFICATE OF COVERAGE

Section 11-46.3, Code of Virginia, requires construction contractors and subcontractors to obtain and maintain workers' compensation insurance while performing work on behalf of the Commonwealth of Virginia departments, institutions or agencies. This same requirement applies for work being performed on behalf of local governments.

Evidence of coverage needs to be provided prior to commencement of work.

This form is to be returned to the organization contracting the work.

The undersigned organization stipulates that it either:

A. Has worker's compensation insurance _____ Yes

Insurance Company: _____

Policy Expiration Date: _____

B. Is self-insured for workers' compensation _____ Yes

Title of Construction Contract:

Demolition of 1120 37th Street for Codes Compliance. – Pkg. #2 - 2010

Contract Number: _____

Signed By: _____

Title: _____

Firm Name: _____

Address: _____

PERFORMANCE BOND

KNOW ALL MEN BY THESE PRESENTS: That we, the undersigned

_____, as Principal,

and _____, as

Surety, acknowledge ourselves held and firmly bound unto the City of Newport News, Virginia

as Obligee, in the amount of _____

dollars, (_____) for the payment of which, well and truly to be made, we hereby

jointly and severally bind ourselves, our heirs, executors, administrators, successors and assigns.

WHEREAS, the said _____ did, on the _____ day of _____, 20____, enter into a contract with the City of

Newport News, Virginia for the Demolition of 1120 37th Street – Pkg. 2- 2010, 2010-4592-

1905, which said contract is by reference made a part hereof, is hereinafter referred to as the

Contract.

NOW THEREFORE, the condition of this obligation is such that if the Principal shall in all respects promptly and faithfully comply with and fulfill all the terms and conditions of said contract, then this obligation shall be void; otherwise it shall remain in full force and effect.

The Surety hereby waives notice of any change, alteration or addition to the terms of the Contract or extension of time made by the Owner. Whenever principal shall be, and declared by Obligee to be in default under the Contract, the Surety may promptly remedy the default, or shall promptly

1. Complete the Contract in accordance with its terms and conditions, or

2. Obtain a bid or bids for completing the Contract in accordance with its terms and conditions, and upon determination by Surety of the lowest responsible bidder, or, If the Oblige elects, upon determination by the Oblige and Surety jointly of the lowest responsible bidder, arrange for a contract between such bidder and Oblige, and make available as work progresses (even though there should be a default or a succession of defaults under the contract or contracts of completion arranged under this paragraph) sufficient funds to pay the cost of completion less the balance of the contract price; but not exceeding, including other costs and damages for which the Surety may be liable hereunder, the amount set forth in the first paragraph hereof. The term "balance of the contract price", as used in this paragraph, shall mean the total amount payable by the Oblige to principal under the Contract and any amendments thereto, less the amount properly paid by Oblige to principal.

It is hereby expressly further understood and agreed that this Bond is also given and made against defective material and workmanship in the said work covered by the said Contract, provided, however, that no suit, action or proceeding, by reason of any defect whatever, shall be brought upon this Bond after one (1) year following the date of final acceptance of the completed project by the Owner.

No right of action shall accrue on this bond to or for the use of any person or corporation other than the Obligee named herein or the heirs, executors, administrators or successors of the Obligee.

SIGNED AND SEALED this _____ day of _____, 20_____.

PRINCIPAL

BY _____

ATTEST:

SURETY

BY _____

ATTORNEY-IN-FACT

COUNTERSIGNED:

Resident Virginia Agent of

Surety

(if original Agent is non-resident)

Approved

As To Form

City Attorney

Submit with Power of Attorney

LABOR AND MATERIAL PAYMENT BOND

KNOW ALL MEN BY THESE PRESENTS: That we, the undersigned, _____
_____, as Principal, and
_____, as
Surety, acknowledge ourselves held and firmly bound unto the City of Newport News, Virginia
as Obligee in the amount of _____
Dollars (_____) for the payment of which, well and truly to be made, we hereby jointly
and severally bind ourselves, our heirs, executors, administrators, successors and assigns.

**WHEREAS, the said _____ did, on the ____ day
of**

**_____, 20____, enter into a contract with the City of Newport News, Virginia,
for**

**the Demolition of 1120 37th Street – Pkg. 2-2010, 2010-4592-1905, which said contract is by
reference made a part hereof, as fully and is hereinafter referred to as the Contract.**

NOW, THEREFORE, THE CONDITION OF THIS OBLIGATION is such that, if Principal
shall promptly make payment to all claimants as hereinafter defined, for all labor and material
used or reasonably required for use in the performance of the Contract, then this obligation shall
be void; otherwise it shall remain in full force and effect, subject, however to the following
conditions:

1. A claimant is defined as one having a direct contract with the Principal or with a
subcontractor of the Principal for labor, material, or both, used or reasonably required for
use in the performance of the Contract, labor and material being construed to also include

that part of water, gas, power, light, heat, oil, gasoline, telephone service or rental of equipment directly applicable to the Contract.

2. The above-named Principal and Surety hereby jointly and severally agree with the

City that every claimant as herein defined, who has not been paid in full before the expiration of a period ninety (90) days after the date on which the last of such claimant's work or labor was done or performed, or materials were furnished by such claimant, may sue on this bond for such sum or sums as may be justly due claimant, and have execution thereon. The City shall not be liable for the payment of any costs or expenses of any such suit.

3. No suit or action shall be commenced hereunder by any claimant:

a. Unless claimant, other than one having a direct contract with the Principal, shall have given written notice of the following:

The Principal, the City, and the Surety above named, within ninety (90) days after such claimant did or performed the last of the work or labor, or furnished the last of the materials for which said claim is made, stating with substantial accuracy the amount claimed and the name of the party to whom the materials were furnished or for whom the work or labor was done or performed.

Such notice shall be served by mailing the same by registered or certified mail, postage prepaid, in an envelope addressed to the Principal, City and Surety, at any place where an office is regularly maintained for the transaction of business, or served in any manner in which legal process may be served in the state in which the aforesaid project is located, save that such service need not be made by a public officer.

b. After the expiration of one (1) year following the date on which Principal ceased work on said Contract, it being understood, however, that if any limitation

embodied in this bond is prohibited by any law controlling the construction

hereof such limitation shall be deemed to be amended so as to be equal to the
minimum period of limitation permitted by such law.

- c. Other than in a state court of competent jurisdiction in and for the county or other political subdivision of the state in which the Project, or any part thereof, is situated, or in the United States District Court for the district in which the Project, or any part thereof, is situated, and not elsewhere.
4. The amount of this bond shall be reduced by and to the extent of any payment or payments made in good faith hereunder, inclusive of the payment by Surety of mechanics' liens which may be filed of record against said improvement, whether or not claim for the amount of such lien be presented under and against this bond.

SIGNED AND SEALED this _____ day of _____, 20_____.

Contractor

BY _____

ATTEST:

Surety

BY _____

ATTORNEY-IN-FACT

Resident Virginia Agent of Surety
(if original agent is non-resident)

Approved
As to Form

City Attorney

Submit with Power of Attorney

SECTION C

SPECIAL CONSTRUCTION CONDITIONS

1. **When the Contractor chooses to work Sunday or any City Holiday, the Contractor shall be required to pay the City for project inspection services for those days. The payment rate is established at \$75.00 per inspector, per hour, for each hour the inspector(s) provides the inspection service, which shall include travel time to and from the site. The Contractor shall submit with each monthly invoice for specific billing period a check payable to the City of Newport News in an amount equivalent to the hours of inspection service times the above rate. There shall be a minimum service time requirement of two (2) hours per inspector.**
2. **The Contractor shall request approval from the City of any scheduled work on Sundays or Holidays a minimum of 72 hours prior to the scheduled work date. Approval by the Director of the Department of Engineering or his representative is required. There is no obligation or requirement that the City provide this service, and the City cannot guarantee the availability of an inspector. Note: This requirement may not apply to contracts where work hour restrictions established by the City will require Sunday or Holiday work.**
3. The contractor shall take all precautions necessary to protect adjacent property. Damage caused to adjacent properties by the contractor shall be repaired at his expense prior to submittal of final estimate for payment.
4. **The contractor shall verify with the Engineer at the start of the project that all required permits have been obtained.**
5. The contractor shall take adequate measures at all times to prevent demolition debris and erosion of soils from entering adjacent properties and streets.
6. The contractor shall provide a minimum of 4" of clean top-soil, fine graded over the area disturbed upon completion of all demolition and removal. Fine grading shall be done to bring property back to grade with existing surrounding properties and to ensure proper drainage. Fine grading shall be inspected and approved by the Engineer prior to placing grass seed and straw.
7. Unless otherwise stated herein, all work shall be done in accordance with these technical specifications and the Department of Engineering Standard Specifications. A copy of the Standard Specifications shall be obtained from the Engineering Department at a cost of \$15.75 and **must be kept on the job site at all times.**
8. The Contractor shall type on his final estimate for payment the following statement:

"I certify this final payment to be just and true for work performed by (Contractor Name) and upon receipt of Balance Due, do hereby release the City of Newport News for all liabilities, obligations and claims upon Contract No. _____."

9. Contractor shall obtain a **Right of Way permit** for all demolition projects. Land Disturbance and Erosion Control agreement and \$75.00 fee is not required for 1120 37th Street since the area to be disturbed is less than 2,500 square feet.

10. **“New Sewer Cap Inspection Requirements”**: In response to problems identifying sewer cap locations after demolition activities, new requirements have been adopted by the Department of Codes Compliance. It is the Contractors responsibility to determine which condition exists for each property. Capping of sewer lateral shall be accomplished prior to obtaining the demolition permit. Contractor shall strictly adhere to Item #17 of this section pertaining to walk-through of property.

The projects **with existing clean-outs** require the installation of a permanent cap or pipe plug within three (3) feet of the cleanout on the house side of the lateral. Flow-able fill (quikrete, etc.) is no longer an acceptable method of capping the sewer lateral. The demolition contractor will be permitted to perform this phase of the project with existing clean-outs. The Engineering Inspector will be permitted to witness the capping or plugging of lateral only for existing clean-out situations and shall forward confirmation of sewer lateral capping to Codes Compliance

The projects **without existing clean-outs** require the Contractor to employ a Licensed Plumber to perform all necessary plumbing work and contact Codes Compliance for all inspection requirements. Sanitary sewer shall be located at right of way. Contractor is responsible for the installation of and maintaining appropriate barricades around excavation until a Codes Compliance Plumbing Inspector approves work and excavation is filled. A Licensed Plumber shall cut the sanitary sewer, install a combination wye, and bring the clean-out to ground level. The house side of combination shall have a permanent cap or plug installed. Joints underground shall be solvent weld or a shielded ferenco type. A cast iron clean-out box shall be installed at ground level around clean-out. All work shall be inspected and approved by a Codes Compliance Plumbing Inspector prior to filling excavation.

(See end of these specifications for sketches illustrating these requirements)

11. The structure, lot, and area of 1120 37th Street shall be completely demolished, cleared, graded and seeded within 7 (seven) days, minus Sundays and Holidays, from the “Notice to Proceed”. Liquidated damages of \$300.00 per calendar day will be assessed for each day that the contract is not completed within the time frame indicated.

12. Demolition Permit fees will be assessed by the Department of Codes Compliance for this Codes Condemnation project at 1120 37th Street. Plumbing permit from Codes Compliance may be required (*reference Item #10 of this section*) with Plumbing permit fees being charged for this Codes Compliance condemnation project. Department of Engineering permit fees, i.e. Right of Way, Land Disturbance, will also be assessed as required.

13. Contractor shall contact the Department of Engineering for final inspections for contractual requirements and shall also contact the Department of Codes Compliance for final inspections required for permits obtained from Codes for the demolition project.

14. Contractor shall not leave structures partially demolished overnight. Safety concerns shall not allow for this condition to exist in the demolition process of residential structures.

15. No work on these projects shall be subcontracted without prior written approval from the Department of Engineering. Any work performed by a subcontractor prior to the General Contractor obtaining written approval from the Department of Engineering will result in non-payment for that portion of work done.
16. Contractor shall be responsible for all submittals per 40 CFR part 61, subpart M- National Emission Standard for Hazardous Air Pollutants (NESHAP). If submittals are required Contractor shall send written notice by facsimile or certified mail, return receipt, for demolition work being performed to the following and **submit copies of these notices to the Engineer prior to start of work.**

Asbestos Control Clerk
Department of Labor and Industry
Powers-Taylor Building
13 South Thirteenth Street
Richmond, VA 23219

Asbestos NESHAP Coordinator
3WC32
U.S. EPA, Region III
1650 Arch Street
Philadelphia, Pa 19103

17. Contractor shall not mobilize any equipment on the project site for any reason nor will a “Notice to Proceed” be issued until he has met with the Project Inspector for field verification of pre-existing damages to all right-of-ways, i.e., sidewalks, drive-way aprons, etc. and to determine route of access to property. If “Notice to Proceed” is erroneously issued prior to this meeting it shall still be the Contractors responsibility to schedule the meeting prior to mobilization. Failure of Contractor to schedule this meeting shall cause Contractor to be responsible for any/all damages regardless of whether damages are pre-existing. Final payment will not be made until damages are repaired and/or replaced.
18. Contractor is responsible for removal and legal disposal of all asbestos-containing material, removal and legal disposal of all personal property from within the structure, demolition of the structure, removal and legal disposal of all debris, and clearing, grading and seeding of the areas disturbed per these specifications.
19. The Department of Engineering has already requested utility disconnects for demolition projects and started the application for demolition permit by requesting the property measurements. All utility disconnect confirmations are being forwarded to the Department of Engineering. Contractor shall be advised when all utility disconnects have been received by this office and all insurances have been approved by the City Attorney’s Office. “Notice to Proceed” shall then be issued and the Contractor shall have the allotted time in the contract to complete the project or liquidated damages will be assessed. **Contractor shall not enter properties for any demolition activities until a contract or purchase order has been issued and a “Notice to Proceed” is in the Contractors possession.**

PART I

ENVIRONMENTAL INFORMATION AND REQUIREMENTS

ASBESTOS-CONTAINING MATERIALS (ACM)

Contractors shall not compact demolition debris by continually running over the rubble with heavy equipment in order to create fewer loads of debris. This practice renders ACM friable and would require disposal of all debris from the site as friable asbestos.

*Contractor shall call for an inspection of abatement work prior to demolishing any structure requiring removal of ACM. **Failure to call for an inspection prior to demolition will result in non-payment for any and all work done for that particular structure.***

An asbestos survey has been conducted of 1120 37th Street. Transite siding has been identified behind the brick veneer on the first floor and possibly behind the aluminum siding of the second floor. Contractor shall remove the transite siding during demolition, keep wet during demolition activities, and dispose of properly.

Roofing material and floor tiles have been assumed to be ACM. All roofing material and floor tiles are considered Category I Non-Friable ACM in good condition and will be left in place during demolition. Contractor assumes ownership of all debris generated from the demolition of the structures with building debris disposed of in a landfill that is permitted to accept Category I Non-Friable ACM.

Contractor, per the NESHAP, 40 CFR Part 61, subpart M, shall be responsible for the proper removal and legal disposal of all ACM identified for removal prior to demolition and any undetected ACM found during demolition. *If the demolition contractor should detect any suspicious materials during the demolition process he shall immediately stop work and notify the Department of Engineering.*

All ACM waste generated from this/these projects shall be disposed of in a landfill permitted to accept Category I Non-Friable ACM, Category II Non-Friable ACM or an E.P.A approved landfill for disposal of Friable ACM. Final payment shall not be made until a waste shipment record has been received by the City to verify proper disposal. Contractor shall be responsible for complying with State and Federal laws. The following regulations are incorporated into these specifications in their entirety:

29 CFR 1926.1101 - Revised OSHA Asbestos Standard for Construction

40 CFR part 61, subpart M - National Emission Standard for Hazardous Air Pollutants
(NESHAP)

OTHER ENVIRONMENTAL CONCERNS

Contractor shall be responsible for the reclaiming of all refrigerants within the HVAC systems that may be a part of this structure to be demolished. Contractor shall be in compliance with all Federal and State Regulations at all times. Contractor shall submit certification that states either all refrigerants were reclaimed or none was present at the project sites. ***Final payment shall not be authorized until such certification has been received.***

Contractor shall be aware that if any underground tanks are found the Contractor shall be responsible for removal of any product found in the tank and the removal and disposal of the tank. Payment for the product removal will be actual invoice plus **10** percent. Tank removal payment will be \$1.00 per gal/tank size for tank sizes up to **1500** gallons. Example would be: \$1.00 per gal/tank size @ 500 gallon tank = \$500.00. Tank sizes above **1500** gallons will be removed at a cost that will be negotiated prior to removal and disposal.

Contractor shall also be aware that due to the age of these structures there is the possibility of the presence of **lead-based paint**. Should the Contractor desire to take samples, all sampling shall be accomplished at no cost to the City and in the presence of a Virginia Lead licensed Department of Engineering staff member or a Virginia licensed Lead Inspector. All Toxicity Characteristic Leaching Procedure (**TCLP**) sampling, if required, will be done by licensed Department of Engineering staff at City expense. It shall be the responsibility of the Contractor to be in compliance with all Federal and State regulations during the entire demolition process at no additional cost to the owner. The following regulations are incorporated into these specifications in their entirety:

29 CFR 1926.62 – Lead Exposure in Construction

29 CFR 1910.1025 – Lead Exposure in General Industry

PART II

GENERAL CONDITIONS

BUILDING DEMOLITION/SITE DEMOLITION

GENERAL DEMOLITION

1. The Work involved in the Demolition and Site Clearance activities, under this contract, includes demolition, removal, and disposal off-site of all:
 - Structures
 - Foundation and Walls
 - Garages and Sheds
 - Concrete Slabs
 - Sidewalks
 - Rubbish, Trash, Junk, Tires
 - Underground Storage Tanks and Piping ** See Other Environmental Concerns
 - Aboveground Storage Tanks, Piping and Product
 - Vaults
 - Cesspools, Septic Tanks
 - Basements
 - Footers
 - Walls and Floors
 - Trees
 - Fencing
2. All rubbish, trash and junk (not otherwise identified) even though not a part of the demolished buildings, shall be removed and the site left clear of such materials.
3. Barricades around certain areas shall be erected as required by the Departments of Engineering and Codes Compliance. It shall be the responsibility of the Contractor to contact these departments to determine where barricades are required.
4. Electrical Services: ***Virginia Power has been notified*** that all electrical services should be disconnected from the subject buildings and site. The contractor shall be responsible for cutting off and disposing of all abandoned electrical cables to a depth of one foot below the surface of the ground.
5. Domestic Water Services: ***The Department of Public Utilities for the City of Newport News has been notified*** that water services to the subject buildings and site should be disconnected at the water meter. The contractor shall be responsible for cutting the existing water lines outside of the subject building and removing and disposing of all water lines within the entire complex.

6. Miss Utility: The contractor is responsible for contacting "Miss Utility of Virginia" by telephoning 1-800-552-7001, at least 72 hours prior to beginning work to demolish the existing buildings.
7. Natural Gas Services: *Virginia Natural Gas has been notified* that gas service should be disconnected. The contractor shall contact Miss Utility as a final check for natural gas service lines in the vicinity of the subject building.
8. Telephone Services: The contractor shall be responsible for cutting and disposing of all existing telephone service cables to a depth of one foot below the surface of the existing ground.
9. Permits: The contractor shall be responsible for obtaining all permits as required by the Departments of Codes Compliance and Engineering for the demolition of the subject structures and utilities. *See Special Construction Conditions item #12.*
10. The Contractor shall prevent or control to the satisfaction of the Department of Engineering, any dust that may result from any demolition operations. Hydrant meter application and information can be obtained on the internet by going to <http://www.nngov.com/waterworks/downloads/firehydrantmeterapplication> or by calling the Meter Shop, Lee Hall Maintenance & Operations Center, 425 Industrial Park Drive, 234-4913.
11. All structures, including buildings, sheds, platforms, steps, stoops, and all other accessory and incidental structures shall be demolished and removed off site. Remove wooden fence in rear of 1120 37th Street on the east side.
12. All masonry walls and concrete slabs shall be demolished and removed off site. No concrete or masonry shall be permitted in material used for backfilling subsurface areas.
13. **Within the immediate vicinity of the main structure**, all trees, bushes and shrubs shall be removed, including the entire root ball.
14. All rubbish, debris, unstable and combustible material of every kind, including asphalt, wood, paper, tires, rags, and plaster, as well as incombustible material, including metal, and masonry will be removed from the area during the process of the work. Upon completion of the work, the site will be free of all debris except material used for backfilling.
15. No person who is not on the Contractor's payroll may be allowed on the site and/or engage in work covered by this Agreement.
16. No burning shall be permitted on the site. All combustible materials shall be disposed off site by the Contractor in accordance with all local regulations.
17. All structures are to be demolished on site and not sold to other parties, without specific, written approval by the City.

18. It shall be the responsibility of the Contractor to determine if there is an adequate disposal area for the materials and debris resulting from the demolition operations.
19. The Contractor shall furnish all materials required for filling of subsurface areas including basements, cellars, wells, cesspools/septic tanks and all other holes or depressions to the existing grade level. Fill materials shall be of a quality acceptable to the Engineer. Sufficient quantities of acceptable fill shall be on hand to ensure uninterrupted progress in completing the backfilling of all subsurface areas.

SPECIAL TRAFFIC CONDITIONS

1. The contractor shall not block any street at any time.
2. The contractor shall restore/repair any right-of-way damages during the demolition. Any damages shall be repaired by the contractor at his expense prior to submittal of final invoice. **See Item #17 of Special Construction Conditions.**
3. The contractor must obtain a right-of-way permit and provide traffic control and signage to direct vehicular and pedestrian traffic as needed or required by the Department of Engineering.

BACKFILLING AND GRADING

1. The demolition of all structures shall be complete and all subsurface areas within the limits of the contract shall be completely cleared of all unstable or combustible material before any backfilling operations begin.
2. The contractor shall furnish at his expense, any and all additional materials required for filling subsurface areas. Said materials shall be of a quality acceptable to the Department of Engineering.
3. No unstable or combustible materials such as wire, plaster, wallboard, wood, roots or other deleterious material and debris that would prevent proper consolidation and compaction or that will cause subsequent settlement will be permitted in the fill. Any material encountered during the demolition process which the contractor might propose to use as fill shall be stockpiled away from all demolition debris and shall be approved by the Department of Engineering prior to use.
4. No masonry shall be permitted in any fill.
5. The surface area disturbed for the project, including areas of overgrowth, shall be free of all debris, brick, concrete, tires, stone, wood, roof shingles, metal, all demolition debris, etc., *larger than 2-inches in any dimension*, upon completion.
6. Once the site has been cleared it shall be the responsibility of the contractor to bring the grade level with existing surrounding properties.. Contractor shall grade so as to leave the site free of any ponding or standing water. Grading shall be accomplished so as to achieve proper drainage.
7. Fine grading shall be inspected and approved by the Engineer prior to placing grass seed. Upon completion of fine grading, with a minimum of 4" of clean top-soil, the area disturbed for the project shall be covered with seed and straw. Hydro-seeding may be used in place of seeding and hay.
8. The contractor shall adhere to all erosion control regulations and must obtain a land disturbing permit or agreement as required by the Department of Engineering if the area to be disturbed is equal to or greater than 2,500 square feet. **See Special Construction Conditions Item #9.**

SEEDING

GENERAL

1.1 DESCRIPTION OF WORK

The Contractor shall furnish all labor, supervision, material, tools, equipment, supplies, and services; and, shall perform all Work necessary for providing and applying fertilizer, lime, seed and mulch in the quantities specified for areas designated on the Drawings or selected by the Engineer.

1.2 Seed:

- A. Seeds shall comply with applicable state and federal seed laws and the Contract Documents.
- B. Seed shall be subject to inspection by the Virginia State Seed Regulatory Inspectors of the Virginia Department of Agriculture and Consumer Services.
- C. Seed test shall be completed within the twelve-month period prior to the time the seed is to be used.
- D. Seed shall not be, or have been, stored in an enclosure where herbicides, kerosene, or other material detrimental to seed germination is stored.
- E. Noxious weed seeds, as defined by the rules and regulations adopted for enforcement of the Virginia Seed Law, will not be permitted. The number of restricted noxious weed seeds shall be not more than the number per ounce or per pound of noxious weed seeds specified in the rules and regulations.

Schedule of Grass Seed Mixture and Application Dates:

Date	Proportion by Weight	Common Name	Botanical	Min. % Germ.	Min. % Pure Sd.	Max. % Weed Sd.
March 1 - Nov. 15	100%	Fescue	Festuca arundinacea	85	98	0.25
Nov. 16 – Feb. 28	100%	Annual Rye Grass	Lolium multiflorum	90	95	0.15

Fertilizer:

- A. Fertilizer shall be uniform in composition, free flowing, and suitable for application with approved equipment.
- B. Ureaformaldehyde shall be slow-release fertilizer material containing 38 percent nitrogen. The material shall have an activity index of 40 to 50 percent as

determined by tests in accordance with the Association of Official Agricultural Chemists.

- C. Fertilizer for general seeding shall be Grade 15-30-15 fertilizer, uniform in composition, free flowing, and suitable for application with approved equipment, and shall be applied at the rate of 600 lb/acre (unless specified otherwise by soil tests).

Lime

- D. Lime shall be agricultural grade ground limestone. Agricultural grade pulverized limestone may be used at no additional cost to the Owner.
- E. The material source shall be registered with and approved by the Virginia Department of Agriculture and Consumer Services in accordance with the Virginia Agricultural Lime Law and shall conform to the following requirements:
- F. Ground limestone shall be of such fineness that at least 86 percent will pass a No. 20 mesh screen, at least 47 percent will pass a No. 60 mesh screen, and at least 28 percent will pass a No. 100 mesh screen. Material shall have a calcium carbonate equivalent of at least 85 percent.
- G. Pulverized limestone shall be of such fineness that at least 90 percent will pass a No. 20 mesh screen and at least 66 percent will pass a No. 100 mesh screen. Material shall have a calcium carbonate equivalent of at least 85 percent.

Mulch:

- H. Mulch for seeding (vegetative) shall consist of dry straw, free from noxious weeds. Mulch shall be reasonably bright in color and shall not be musty, moldy, caked, decayed, or very dusty.

1.3 ****SUBMITTALS**** (New)

Prior to use or placement, the Contractor shall submit certifications in the form of affidavits from the material suppliers, together with supporting data, attesting that the composition of lime, fertilizer, seed and mulch meet specification requirements.

EXECUTION

2.1 PROCEDURES

- I. Seeding operations shall not be performed when the ground is frozen or when soil or weather conditions would prevent proper soil preparation and subsequent operations. When hydroseeding is performed, nozzles or sprays shall not be directed toward the ground in a manner that will cause erosion or runoff. The

Contractor shall notify the Engineer at least 48 hours prior to beginning seeding operations.

- J. Lime shall be uniformly applied to areas to be seeded at the rate of 2 tons per acre (unless specified otherwise by soil tests). Any approved method may be used.
- K. After lime has been applied, areas to be seeded shall be prepared as follows: Slopes 3:1 or flatter shall be loosened to a depth of approximately 3-inches by disking, harrowing, or other approved methods. Loosening of soil on excavated slopes steeper than 3:1 will not be required except to eliminate hard or crusted surfaces. Shoulders and embankment slopes steeper than 3:1 shall be loosened to a depth of approximately 1-inch. Clods, loose stones, and other foreign material larger than 2-inches in any dimension shall be removed and properly disposed of as approved by the Engineer. Gullies, washes, and disturbed areas that develop subsequent to final stabilization shall be repaired before they are seeded.
- L. When dry fertilizer is used, it shall be applied uniformly to the seeding areas at the time of seeding at the rate of 600 pounds of 15-30-15 fertilizer, or an equivalent 1-2-1 fertilizer, per acre (unless specified otherwise by soil tests). The method of application shall be approved by the Engineer before fertilizer is applied.
- M. When in a liquid form or mixed with water, fertilizer shall provide the same value of nutrients per acre as specified for dry fertilizer. Fertilizer applied in liquid form shall be agitated during application.
- N. Seed shall be uniformly applied on prepared areas with fertilizer and mulch and shall conform to the following:
 - 1. For hydroseeding, seed shall be put in the mixture slowly to result in a uniform mixture before application. Hydroseeding mixtures shall be constantly agitated from the time of mixing until application on the seed bed and used within 8 hours from the beginning of mixing.
 - 2. Overseeding shall consist of applying seed and fertilizer on areas prepared as directed by the Engineer.
- O. Mulch shall be applied within 48 hours after completion of the seeding operation. When straw mulch is used, it shall be applied on seeded areas at the rate of approximately 2 tons per acre. When wood cellulose fiber mulch is used, it shall be uniformly applied at the rate of approximately 1,500 pounds (net dry weight) per acre. Mulch will not be required on overseeded areas.
- P. Straw mulch shall be applied to a uniform thickness in such a manner that not more than 10 percent of the soil surface will be exposed. Wet straw shall not be used. Straw mulch shall be anchored to the seeded surface by spraying with wood cellulose fiber at the rate of 750 pounds per acre; spraying with an emulsified asphalt at the rate of at least 100 gallons per ton to mulch in a manner that will protect adjacent property and pedestrian traffic areas; disking or punching the

mulch partially into the soil; using approved netting; or, using other materials or methods approved by the Owner. The Contractor may use more than one method on the same project.

2.2 ESTABLISHMENT AND MAINTENANCE

- A. Areas not showing signs of grass growth shall immediately be reseeded. Protection shall be provided against traffic or other use by erecting barricades, as needed, immediately after treatment is completed, and by placing warning signs, as directed. The Contractor shall assume responsibility for proper care of seeded areas while grass is becoming established for three months after completion of treatment on the entire project, unless desired cover is established in a shorter period of time (desired coverage shall be 90% of total area seeded). When any portion of the surface becomes gullied or otherwise damaged or treatment is destroyed, the affected portion shall be repaired to re-establish condition and grade of soil and treatment prior to injury, as directed. Repair work shall be performed without additional cost.
- B. Mulched areas shall be maintained until all work or designated portions thereof have been completed and accepted. Any damage shall be repaired, and mulch materials that has been removed by wind or other causes shall be replaced and secured.

2.3 CLEANUP AND PROTECTION

- A. The Contractor shall keep pavements clean and work area in an orderly condition.
- B. The Contractor shall protect existing landscape work and materials from damage due to landscape operations, operations by other contractors and trades and trespassers; and, shall maintain protection during installation and maintenance period of three (3) months.

SEWAGE COLLECTION SYSTEMS

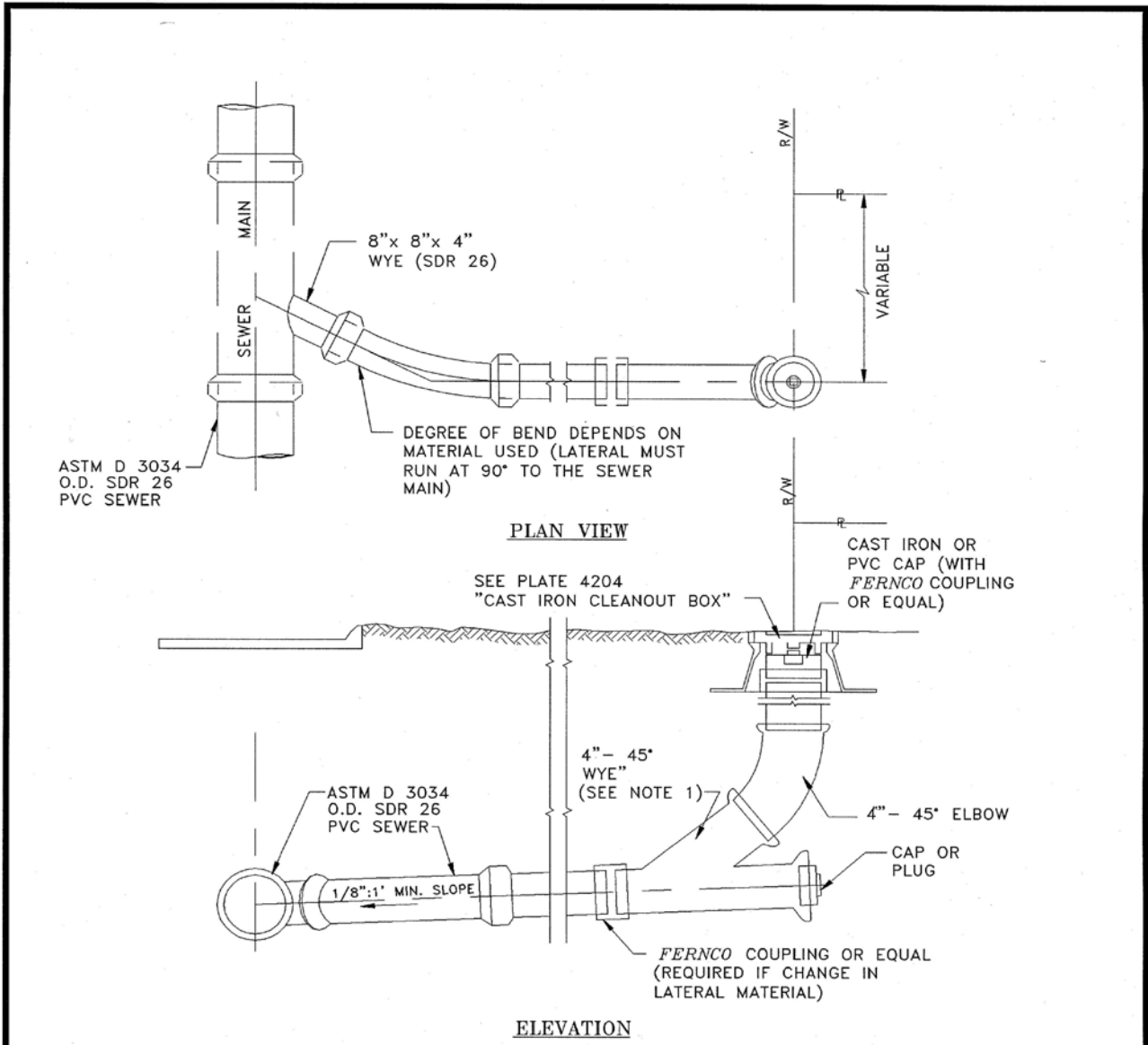

NOTES:

1. Lateral pipe shall be SDR 26, unless due to special circumstances the Director requires the pipe to be ductile iron (D.I.). In either case, the wye (4"x 4"x 4") pipe used in conjunction with the cleanout box may be SDR 35.5 until an SDR 26 wye becomes available in the manufacturing industry.
2. Also see Plate 4202 "Ductile Iron House Lateral for Deep Sewer Main."



Approved August 1997

Mostafa A. Sabbah

MOSTAFA A. SABBABH, Ph.D., P.E.
 Director, Department of Engineering

HOUSE LATERAL

Plate 4201

SEWAGE COLLECTION SYSTEMS

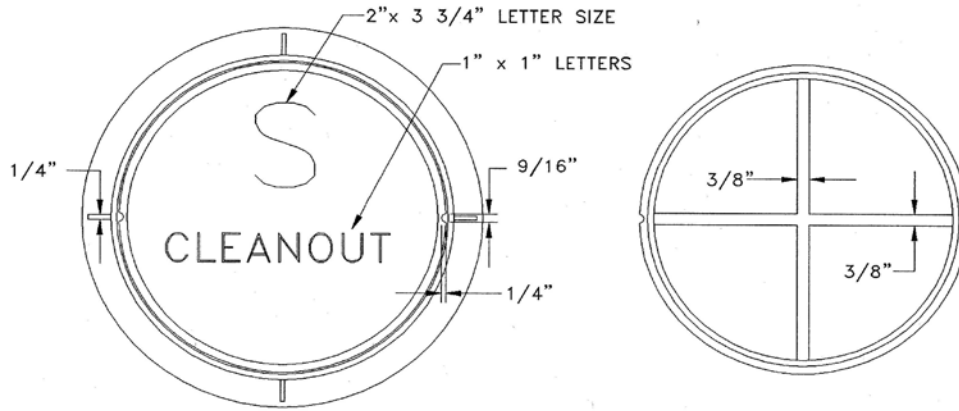

TOP VIEW

BOTTOM VIEW

COVER

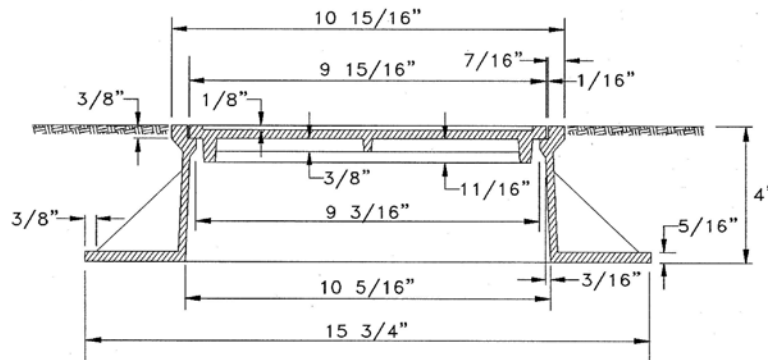

PROFILE



Approved

August 1997

Mostafa A. Sabbah
MOSTAFA A. SABBABH, Ph.D., P.E.
Director, Department of Engineering

CAST IRON
CLEANOUT BOX

Plate 4204